

*61st Annual
Central Texas
Science and
Engineering Fair

Handbook*

SECTIONS

1. Historical Information
2. Current Year
3. General Guidelines
4. Before You Begin
(Student Guidelines)

In association with:

*Intel International Science and Engineering Fair
Society for Science & the Public
Baylor University
Texas State Technical College*

TABLE OF CONTENTS

1. Historical Information

- Purpose/ Board of Trustees 1
- Acknowledgements 2
- History 3
- Eligibility/Local Fairs 4
- Award Winners 5
- Past ISEF Finalists 8

2. Current Year

- Teacher Checklist 10
- Important Dates/Deadlines/Fees 11
- Tentative Schedule of Events 12
- Bryce C. Brown Award 13
- CTSEF Baylor University Scholarship 14

3. General Guidelines

- Rules for All Participants 15
- Ethics Statement/Limitation/Continuation of Projects 17
- Team Projects 18
- Deficiency Form Explanation – SRC, PRT, IRB 19
- PRT/SRC Committee Information 20
- IRB Committee Information 21
- Additional CTSEF Human Participants Guidelines 22
- Display and Safety Regulations 23
- Entry Rules/Judging Rules 24

4. Before You Begin

- Student Checklist 25
- Student Guidelines 27
- Guidelines for Hypotheses 31
- Adults Involved in a Science Project 32
- Category Descriptions 33
- Abstract Instructions 35
- Research Plan Guide 36
- SRC, IRB and PRT Flow Chart 37
- Online Process Flow Chart 38
- Waiver and Release Form 41
- Office Information 42

PURPOSE

The Central Texas Science and Engineering Fair (CTSEF), in association with Society for Science & the Public, is a non-profit organization established under IRS guidelines. Its purpose is to promote interest and expertise in science and engineering among school students in a 13-county region. The CTSEF encourages and inspires students to explore and investigate their world through hands-on research. After conducting research, students present their findings in three-dimensional exhibits that are evaluated by scientists and educators. Students acquire useful scientific knowledge as well as develop critical thinking and problem-solving skills that will help them now and in the future. At the competitions, students have the opportunity to meet students from other schools, exchange ideas, and demonstrate the results of their research. Winners qualify to advance to state and international competitions.

CTSEF is governed by a board of unpaid trustees who work in close cooperation with administrative representatives of Baylor University. Businesses, foundations, organizations, societies, and individuals help support the fair through community donations.

BOARD OF TRUSTEES

Officers

----- **President**
Dr. Janelle Walter, Secretary
Mr. Tom Lindsey, Controller

Mr. Bradley Christian
~~**Mr. Marc Curliss**~~
Mr. Mike Green
~~**Dr. David Grogan**~~
Dr. Diane Hartman
Dr. Benjamin Kelley
~~**Mr. Pat Lea**~~
~~**Mr. Lance Martin**~~
Ms. Melissa Rhoden
Ms. Patricia Scott
Dr. Kenneth Van Treuren

Emeritus Members

Mr. Calvin B. Smith

Fair Co-Directors

Mrs. Linda Morris
Mr. David Lintz

Central Texas Science and Engineering Fair, Inc.
One Bear Place #97356 - Waco, Texas 76798
Baylor University
Cashion Building - Suite 307
Telephone: (254) 753-3093
Email: science_fair@baylor.edu
Website: www.ctsef.org

Office
Elaine Alsup, Office Coordinator

ACKNOWLEDGEMENTS

We extend our sincere thanks to all who helped make the Central Texas Science and Engineering Fair a success through grants, their sponsorship, and donation of service, equipment, materials, and money.

SPONSORS

Baylor University

Texas State Technical College

Scott and White Foundation

L-3 Communications

McLennan Community College

NRG Energy Texas

First National Bank of Central Texas

Walmart Foundation

The CTSEF Board of Trustees

Region XII Education Service Center

Waco Tribune-Herald

Sunbelt Insurance and Associates

Aramark Services

Red Men Museum and Library

IN-KIND CONTRIBUTORS

Domino's Pizza

HISTORY

The Texas Academy of Science made the first attempt to organize and promote a regional science fair in central Texas in the mid-1950s with little success. It was late in 1956 that Baylor University became involved when the Baylor Chapter of The Society of the Sigma Xi provided the leadership to secure a regional science fair charter. Dr. Bryce C. Brown, who was a professor in the Biology Department and curator of the Strecker Museum, was named as director of the fair. Although the study of the sciences was not as emphasized in 1956 as it was to be after the USSR launched the first artificial Earth satellite, Sputnik, on October 4, 1956, Dr. Brown and his colleagues generated enough interest to get the fair started.

Baylor University and Sigma Xi sponsored the first fair on March 29, 1957. There were 40 entries from area schools in Bosque, McLennan, Navarro, Freestone, Limestone, Falls, Bell, Coryell, Somervell and Lampasas counties. The winner in the exact science division was John Jeanes and the winners in the natural science division were Mary Ellen Rogers and Barbara Bruner. All three of the winning students were from Waco High School.

The fair was known as the District X Texas Science Fair, and was affiliated with the National Science Fair. In 1964, the name was changed to the Central Texas Regional Science Fair. After 30 years of growth and expansion, the name was changed again, in 1994, to the Central Texas Science and Engineering Fair, Inc. (CTSEF).

The fair is now affiliated with the Intel International Science and Engineering Fair (ISEF). The CTSEF is one of 13 regional fairs in the state of Texas. Finalists sent to the ISEF have won numerous awards over the past 50 years. Many of the students who have participated in earlier fairs have gone on to earn doctoral degrees in scientific fields. Some have returned to serve as sponsors, judges and board members.

Calvin B. Smith succeeded Dr. Brown as director of the Strecker Museum and director of the fair in 1983. Mr. Smith passed the duties of director to A. Scott Lea, MD, president of Waco Infectious Disease Associates and McLennan County Public Health Director in 1994. Stephen C. Scott, owner of Sydaptic, Inc., followed Dr. Lea as director of the fair in 1998. Following the resignation of Mr. Scott in 2013, Jeanne D. Waggener, R. Ph., Market Health and Wellness Director, Wal-Mart Pharmacy was elected as director of the fair. Under the leadership of each, the long tradition of inspiring students to become involved in science and to develop interests that carry through into adulthood has continued.

In 2016, Jeanne Waggener retired as director and co-directors were appointed in the interim.

REGIONAL FAIR ELIGIBILITY

Any student in grades 6-12 enrolled in a public, private, parochial, military, or home school within the following counties is eligible to try for entry into the CTSEF: Bell, Bosque, Coryell, Falls, Freestone, Hamilton, Hill, Lampasas, Limestone, McLennan, Milam, Navarro, and Robertson.

ALL projects must have been approved for entry by the CTSEF through Scienteer.com prior to the local school fair. Winning at the local level guarantees only that a student is *eligible to apply for entry* in the CTSEF.

Only current year CTSEF forms and applications are used to determine participation and eligibility of a student researcher.

The project submitted to the CTSEF must be the student's own work. It is the student's responsibility to check with the CTSEF for any additional restrictions or requirements.

CTSEF may certify the top three entries from each category of the junior division and senior division to enter state competition. Two Senior Division Individual Finalists and one Team Project Finalist may be certified for international competition. Students must meet all ISEF rules and guidelines and not be over 21 years of age by May 1 of the fair year.

The CTSEF is under contract with Society for Science and the Public and the Intel International Science and Engineering Fair (ISEF) to conduct the regional fair according to the rules and guidelines that ISEF has set. **Participants must observe all the rules in this handbook.** Ignorance of these rules will not excuse anyone from meeting the entry requirements. The purpose of these rules is to provide basic guidance and to protect students, teachers, and parents, as well as human participants and animal subjects.

GUIDELINES FOR LOCAL SCHOOL FAIRS

ALL projects expecting to advance to the regional fair must be approved by the CTSEF prior to experimentation and entry in any local fair.

In order to be approved, a student must follow the rules and guidelines located on the CTSEF website: www.ctsef.org

Student participants will need to complete the online process (Scienteer.com) in order to be eligible. However, this does not guarantee that a student may enter the CTSEF.

Display or poster exhibits showing only library research are not acceptable. Projects must present the results of experimental investigation or field studies that include data gathering and analysis, or engineering based projects. Projects that use only models or demonstrations are not allowed.

NO product testing projects are allowed at the Regional Fair level. Although acceptable at the local level, product testing projects may not advance to the CTSEF.

A student must first enter, participate in, and be judged in a local school fair to be considered for the regional fair competition.

Participation in a local fair, and placing **1st, 2nd, or 3rd** in one of the **22 categories**, will make a student eligible to enter the Regional Fair (CTSEF) in Junior Division (6th - 8th grades) or Senior Division (9th - 12th grades). Schools may enter only the **1st, 2nd, or 3rd** place team winners. Your local school fair may enter only the 1st, 2nd or 3rd place winner, regardless of grade, in one of the 18 categories (team included). [**Example:** A school may enter only the top 1st, 2nd or 3rd place per fair, per category, per school.] **NOT accepted** for entry: 1st, 2nd or 3rd place winners per school grade.

AWARDS

REGULAR AWARDS

A certificate of merit will be awarded to each exhibitor at his or her exhibit.

Regular awards consist of a 1st, 2nd, 3rd place, or Honorable Mentions in each of the 22 senior categories as well as 1st, 2nd, 3rd place or Honorable Mentions in each of the 22 junior categories. Not all places may be awarded each year.

SPECIAL AWARDS

Special Awards are presented by many local, regional, and national organizations. These awards often include certificates, cash, plaques, books, subscriptions, medallions, savings bonds, trophies, T-shirts, etc. Special Award judges may or may not use a similar scoring method as the regular judges since the nature and purpose of special awards varies from organization to organization. Students may or may not be interviewed, depending on each individual organization.

The following organizations have presented awards in the past:

ALCOA Foundation	Central Texas Audubon Society
American Association of University Women – Waco Branch	Clean McLennan County
American Diabetes Association – Waco Chapter	Domelsmith Consumer Award
American Meteorological Society	Eastman Kodak Company
American Water Works Association – Texas Section	Entomological Society of America - Southwest Branch
Association for Women Geoscientists Foundation	Garden Forum Garden Club
Baylor University:	Health Physics Society - South Texas Chapter
Baylor University Scholarship	Heart of Texas Counseling Association
Baylor University Student Union	Hillcrest Baptist Medical Center
Beta Tau Chapter of Beta Beta Beta	Heart of Texas Society of Health System Pharmacists
Biology Department	Intel
Biophilia	Kappa Omicron Nu
Bookstore	Keep Waco Beautiful, Inc.
Chemistry Department	KXXV - TV
College of Arts and Sciences	McLennan County Medical Society
Communication Sciences & Disorders	National Association of Biology Teachers
Earth Science Department	National Association of Corrosion Engineers
Environmental Studies Department	National Council of Teachers of Mathematics
Geological Society	Providence Healthcare Network
Geology Department	Renewable Aviation Fuels Development Center
Mathematics Department	Society for In Vitro Biology
Mayborn Museum Complex	Sydaptic
Neuroscience Society & Psi Chi	Todd Willis Memorial Award
School of Education	Texas State Technical College
Society of the Sigma Xi	TXU Energy
Sigma Pi Sigma & Department of Physics	United States Army
Blue Bell Creameries LP	United States Dept. of Health & Human Services
Broadcom MASTERS	United States Metric Association
Cameron Park Zoo	United States Navy and Marine Corps
Central Texas Audubon Society	Waco Hilton Inn
Central Texas Chapter, Texas Society of Professional Engineers	Water Environment Association of Texas
Central Texas Dental Society	Yale Science and Engineering Association
City of Waco Solid Waste Department	

THE BRYCE C. BROWN AWARD

Each year, in honor of Dr. Bryce C. Brown, the CTSEF founder and first director, an award is given to the most promising young scientist regardless of age or category. Only ONE STUDENT FROM EACH SCHOOL is eligible to qualify for this award. Nominees must be recommended by their school science teacher after demonstrating their proficiency and interest in the scientific method.

This award is one of the most prestigious offered by the CTSEF. Nominees demonstrate both a continuing interest in science or engineering, and intent to pursue a science-related career. The Bryce C. Brown Award will not be awarded more than once to the same student.

Past winners are:

1984	Alan Gilchrest	7 th	Robinson Jr. High	Environmental Science
1985	Matthew Madenka	8 th	Wiley Middle	Behavioral & Social Sciences
1986	Norman Y. Ho	11 th	Ellison High	Biochemistry
1987	Zach Coombs	12 th	Waco High	Engineering
1988 (tie)	Chia Ming Wang	12 th	Waco High	Microbiology
1988 (tie)	Rene Drummond	12 th	Rockdale High	Behavioral & Social Sciences
1989	Dawn Landua	8 th	Midway Jr. High	Behavioral & Social Sciences
1990	K. Layne Gossett	12 th	Rockdale High	Medicine & Health
1991	Hayley Voige	10 th	Waco High	Behavioral & Social Sciences
1992 (tie)	Kelly W. Gossett	11 th	Rockdale High	Engineering
1992 (tie)	Kevin W. Stafford	12 th	Troy High	Earth & Space Science
1993	Jay T. Sartain	9 th	Midway High	Behavioral & Social Sciences
1994	Peter Crossno	12 th	Rockdale High	Microbiology
1995	Matt Ferguson	12 th	Rockdale High	Zoology
1996	Melissa Baumann	8 th	O. J. Thomas Jr. High	Microbiology
1997	Alicia Willson	10 th	Robinson High	Microbiology
1998	Steven Sielaff	12 th	Robinson High	Earth & Space Science
1999	JonCee Kelley	12 th	C. H. Yoe High	Environmental Science
2000	Bennett Lane	8 th	Midway Middle	Behavioral & Social Sciences
2001	Timothy Hartland	8 th	Midway Middle	Engineering
2002	Laura A. Hartman	11 th	China Spring High	Microbiology
2003	David Martin	8 th	St. Louis School	Microbiology
2004	Lindsay Liles	10 th	C. H. Yoe High	Microbiology
2005	Amanda Hartman	12 th	China Spring High	Microbiology
2006	Tara Gloyna	11 th	Temple High	Environmental Science
2007	Hannah Davis	12 th	C. H. Yoe High	Behavioral & Social Sciences
2008	Sandy Ren	9 th	Midway High	Team Category
2009	Logan Kostroun	12 th	C. H. Yoe High	Plant Sciences
2010	Julia McKnight	8 th	Midway Middle	Behavioral & Social Sciences
2011	Linda Ren	9 th	Midway High	Biochemistry
2012	Camille Roberts	8 th	Midway Middle	Behavioral & Social Sciences
2013	Edward Kim	8 th	Midway Middle	Energy/Transportation
2014	Alana B. Armstrong	8 th	Waco Baptist Academy	Environmental Management
2015	Caroline Kutach	12 th	Midway High	Animal Science
2016				

BAYLOR UNIVERSITY SCHOLARSHIP AWARD

Students in their junior or senior year of high school who have qualified for entry in any category in the Central Texas Science and Engineering Fair may apply for the Baylor University Scholarship. The scholarship award provided \$1000 tuition to Baylor University. This amount was increased to \$2000 beginning in 2006. This amount was increased to \$4000 beginning in 2011.

Past winners are:

1998	Steven Sielaff	12 th	Robinson High	Earth & Space Science
1999	Nina Hathi	12 th	Robinson High	Mathematics
2000	Kyle Conklin	11 th	C. H. Yoe High	Botany
2001	Erica Maresh	10 th	Mexia High	Chemistry
2002	Laura A. Hartman	11 th	China Spring High	Microbiology
2002	Jared Locklear	12 th	C. H. Yoe High	Environmental Science
2003	Laura A. Hartman	11 th	China Spring High	Microbiology
2004	Amanda Hartman	11 th	China Spring High	Microbiology
2005	John Hertenberger	11 th	C. H. Yoe High	Environmental Science
2006	Haley N. Wasson	12 th	Ellison High	Biochemistry
2007	Stephanie Simcox	11 th	McGregor High	Cellular and Molecular
2008	Stephanie Simcox	12 th	McGregor High	Cellular and Molecular
2009	Kristen Kylberg	12 th	Temple High	Team Category
2010	Not awarded			
2011	Not awarded			
2012	Not awarded			
2013	Nicholas St. John	12 th	Whitney High	Chemistry
2014	Lauren Strickland	11 th	Central High	Biochemistry
2015	Not awarded			
2016				

PAST ISEF FINALISTS

1957	Mary Ellen Rogers John Jeanes Barbara Bruner	Waco High Waco High Waco High	1978	Michael S. Wren 4th - Grand Award- ISEF Earth & Space Science Marina Hsieh	Killeen High Richfield High
1958	Julian Sewell Elizabeth Janeway	Belton High University High	1979	David Schechter 3rd - Grand Award - ISEF Biochemistry Felicia K. Park	Richfield High Richfield High
1959	Estelle Jares John Fitzpatrick	West High Marshall High	1980	Bill Richter 4th - Grand Award - ISEF Earth & Space Science 2nd - U.S. Air Force Tamara Hebert	West High Rockdale High
1960	Gerald Birdwell Jim Brocker	Eagle Lake High Temple High	1981	Colin Valentine Ronald Rummel	Rockdale High Yoe High
1961	Jim Brocker Gabriele Luthardt	Temple High Killeen High	1982	----- Tamara Hebert Honorable Mention - Eastman Kodak Co. Honorable Mention - USAF	Richfield High Rockdale High
1962	Bart Reilly Edward Erwin	Corsicana High Corsicana High	1983	David Boutwell 2nd - Grand Award - ISEF Environmental Sciences 2nd - American Society of Civil Engineers 2nd - U.S. Navy 5th - American Association of Petroleum Engineers John Ho	Yoe High Ellison High
1963	Bobby Fauvelle Stephen Tuttle	Corsicana High Temple High	1984	Chia-Ying Wang Russell Yakesch	Richfield High Rockdale High
1964	Ken Smith Connie Bullock	University High Hico High	1985	Kerry Sagebiel Honorable Mention - Eastman Kodak Co. Chia-Ying Wang	Rockdale High Richfield High
1965	Jeff Bentley Jan Flowers	Temple High Richfield High	1986	Kerry Sagebiel 3rd - Grand Award - ISEF Earth & Space Science Honorable Mention - Eastman Kodak Co. Norman Ho	Rockdale High Ellison High
1966	Jeff Bentley Barbara Jackson	Temple High Killeen High	1987	Kerry Sagebiel Rene Drummond	Rockdale High Rockdale High
1967	Lisle Posey Cynthia Torrance	Mexia High Waco High	1988	Rene Drummond Chia-Ming Wang Honorable Mention - Eastman Kodak Co.	Rockdale High Waco High
1968	Wilson Erwin William Brown	Corsicana High Lampasas High	1989	Michael Sterling	Waco High
1969	James Harper Patrick Gibson	Copperas Cove High Corsicana High	1990	Layne Gossett 2nd - Grand Award - ISEF Medicine & Health 1st - Eastman Kodak Co. 3rd - Optical Society of America 3rd - Society of Photographic Scientists/Engineering	Rockdale High
1970	John Hawk Patrick Gibson	Corsicana High Corsicana High	1990	Danny Drummond 1st - Eastman Kodak Co. 2nd - Society of Photographic Scientists/Engineering	Rockdale High
1971	James Nance Donald Parker	Yoe High Copperas Cove High			
1972	Steve Shehorn Donald Parker	Robinson High Copperas Cove High			
1973	William Duncan Gary Fuchs	Copperas Cove High Yoe High			
1974	Gary Fuchs David Hollas	Yoe High Yoe High			
1975	Newton D. Farrar William S. Smith	Hico High Richfield High			
1976	Dana Snipes Philip Frederick	Groesbeck High Tennyson Jr. High			
1977	Brian Linver Gary Frenzel	Killeen High Tennyson Jr. High			

1991	Danny Drummond	Rockdale High	4th ISEF Grand Award - Microbiology
	4th - Grand Award -		
	ISEF Earth & Space Science		
	1st - Eastman Kodak Co.		
	1st - U.S. Navy Earth & Space Sciences		
	Honorable Mention - NASA		
	Kevin Stafford	Troy High	
1992	Danny Drummond	Rockdale High	
	3rd - Grand Award -		
	ISEF Earth & Space Science		
	3rd - Eastman Kodak Co,		
	Kevin Stafford	Troy High	
	4th - Grand Award -		
	ISEF Earth & Space Science		
	Merit - Society of Exploration		
	Geophysicists		
	Honorable Mention – Society for		
	Mining, Metallurgy, & Exploration		
1993	Danny Drummond	Rockdale High	
	Eastman Kodak Award		
	U.S. Marine Corps Office of Naval		
	Research and Scholarship Award		
	Erica Phillips	Rockdale High	
1994	Jay Sartain	Midway High	
	4th - Grand Award -		
	ISEF Behavioral & Social Sciences		
	1st - U.S. Air Force		
1995	Jay Sartain	Midway High	
	Honorable Mention - Association for		
	Behavioral Analysis		
	Matt Ferguson	Rockdale High	
	1st - U.S. Air Force		
	Team: Robin Melcher, Candice Diver,		
	Rhya Taylor	Rockdale High	
1996	Jay Sartain	Midway High	
	3rd - Grand Award		
	ISEF Behavioral & Social Sciences		
	Teri Burgett	Rockdale High	
	Team: Kevin Kelly, Kyle Gibson		
		Waco High	
1997	Deanne Masur	Rockdale High	
	Sondra Beissner	Temple High	
	Honorable Mention-Eastman Kodak Co.		
	Team: Julie Burns, Jenny Gebhart		
		Rockdale High	
1998	Steven Sielaff	Robinson High	
	1st - U.S. Air Force		
	JonCee Kelley	Yoe High	
1999	Alicia Willson	Robinson High	
	Melissa Baumann	Yoe High	
2000	Melissa Baumann	Yoe High	
	Kyle Conklin	Yoe High	
2001	Stephanie Gelner	Yoe High	
	Lacey Vaculin	Yoe High	
	Honorable Mention Endocrine Society		
2002	Jeffrey Easterwood	Rockdale High	
	Amanda Hartman	China Spring High	
2003	Team: Sarah May, Karianne Wood		
		Mexia High	
	Amanda Hartman	China Spring High	
2004	Amanda Hartman	China Spring High	
	4th ISEF Grand Award - Microbiology		
	Florida Institute of Technology Scholarship		
	Oregon State University Scholarship		
	Tara Gloyna	Temple High	
2005	Tara Gloyna	Temple High	
	2nd ISEF Grand Award - Environmental		
	Science		
	Society of Environment Toxicology		
	& Chemistry Award		
	Lindsay Liles	Yoe High	
2006	Tara Gloyna	Temple High	
	3rd ISEF Grand Award - Environmental		
	Science		
	Society of Environment Toxicology		
	& Chemistry Award		
	Lindsay Liles	Yoe High	
2007	Tara Gloyna	Temple High	
	2nd ISEF Grand Award - Environmental		
	Science		
	U.S. Air Force Award		
	Stephanie Simcox	McGregor High	
2008	Stephanie Simcox	McGregor High	
	Logan Kostroun	Yoe High	
2009	Logan Kostroun	Yoe High	
	3rd ISEF Grand Award – Plant Sciences		
	Claire Gamino	Temple High	
	Team: Kristen Kylberg, Shereen Rabie,		
	Areej Rabie	Temple High	
2010	Nisha Pillai	Temple High	
	Sandy Ren	Midway High	
	Florida Institute of Technology Scholarship		
2011	Jack Rhoades	Yoe High	
	Nisha Pillai	Temple High	
2012	Iyan Younus	Yoe High	
	Devin Buchanan	Yoe High	
2013	Thomas Tow	Yoe High	
	Linda Ren	Midway High	
2014	Lauren Strickland	Central High	
	Darin Garrett	Harker Heights High	
2015	Edward Kim	Midway High	
	4th ISEF Grand Award -		
	Lauren Willey	Yoe High	
2016	Edward Kim	Midway High	
	1 st ISEF Grand Award - Biochemistry		
	Lauren Wiley	Yoe High	

TEACHER CHECKLIST

- READ:** Pay particular attention to and read and study this handbook thoroughly and carefully.
- SUBMIT BY PRE-APPROVAL DEADLINE:**
 - ◆ Required forms and paperwork
Every student and his/her parent must complete and submit a **Waiver and Release of Liability Form** in order for CTSEF to process his/her paperwork
 - ◆ \$5 Filing Fee per student for pre-approval
All research projects: The research plan and all applicable forms must be completed and returned to the CTSEF office with a filing fee for each student before the pre-approval deadline (see "Important Dates and Deadlines"). **All paperwork and Forms must be in proper order.**
- ADDRESS DEFICIENCIES AND RESUBMIT BY CORRECTION DEADLINE:**
 - ◆ Deficiency
A Deficiency listing for any corrections will be returned to you with your online paperwork to your student account.
 - ◆ Paperwork must be resubmitted
The student and teacher must read each comment, as corrections are made and return the corrected project to the CTSEF for a second review online to: www.ctsef.org. All online paperwork is required to be return until the online process is complete. Once this process is complete you will be instructed to make a copy of everything that the reviewers have reviewed (online) and given a status of online complete (at this point the online process complete) the student/teacher must mail or bring a copy of your online completed (original signed wavier, a copy of all forms, research plan, bibliography, graphs, diagrams or charts to the CTSEF office. This is the students' final review for approval and signature from the CTSEF committee chair.
A student's project is approved to begin experimentation ONLY when the committee chairperson has signed the Approval Form (1B) and stamped "Approved" on the front of the student's paperwork.
- SUBMIT BY ENTRY DEADLINE:**
 - ◆ Official Entry Form
All entries must be submitted on a current Official Entry Form in order to compete at the CTSEF. Failure to properly complete Entry Form, including signatures, may result in disqualification. Only the 1st, 2nd, and 3rd place winners in each category may enter the CTSEF from the local school science fair in junior (6-8 grades), and senior division (9-12 grades). All Team projects compete in a "teams" category.
 - ◆ All approved and necessary forms **plus a \$7 entry fee per student.**
All required forms, a copy of the abstract, and the entry fee must be included with the Entry Form.
Each student's (or team of student's) **paperwork must be stapled in numerical order.**
Continuation of previous year(s) research must include all abstracts and research plans, properly dated and in order.
LATE APPLICANTS WILL NOT BE ACCEPTED FOR ENTRY.
No last-minute changes will be made at the fair for inaccurate information submitted on forms.
Entry fees will not be refunded if a student fails to enter the CTSEF. No exceptions.
 - ◆ Applications for the Bryce C. Brown Award and Baylor University Scholarship Award (if applicable).
- REGISTER STUDENTS** at the TSTC Murray Watson Student Recreation Center at registration between 8:00 and 10:00 a.m. on Tuesday.
- ATTEND** the Teacher's Meeting at 6:00 p.m. on Tuesday evening.
- PLAN** for late judging on Tuesday evening. Dismissal of students will be no later than 10:00 p.m.
- ATTEND** the proper Awards Ceremony on Wednesday. (Awards ceremony times may vary)

IMPORTANT DATES AND DEADLINES

Regional Science Fair (CTSEF):	February 21 - 22, 2017
State Science Fair (EMTSEF):	March 31 - April 1, 2017
International Science Fair (ISEF):	May 14 - 19, 2017

DEADLINES:

PRE-APPROVAL: All paperwork must be received by 5:00 p.m. the first and third Tuesday of each month. The last deadline date to submit any new projects for initial review is December 2, 2016. NO EXCEPTIONS.

* September 2 * September 16 * October 7 * October 21 * November 4
* November 18 * December 2 (no new projects allowed after this date) * December 16 (**last review**)

FINAL CORRECTIONS	Friday, January 6, 2017
ENTRY FORMS	Friday, February 3, 2017
BRYCE C. BROWN AWARD APPLICATION	Friday, February 3, 2017
BU SCHOLARSHIP AWARD APPLICATION	Friday, February 3, 2017

IRB Interviews:

Regional IRB interviews **may** be required of students and will be conducted on a monthly basis. This will occur only if the IRB committee requests an interview and the student has an assigned interview time. It is the responsibility of the Teacher/Sponsor or student/s to contact the CTSEF office to schedule the interview. Students are required to attend the interview with **a copy of their online submitted paperwork**. The location and starting time of the IRB interview will be emailed to the Teacher/Sponsor and student/s. In some cases, a telephone interview can be scheduled with the IRB committee.

Additional review dates may be scheduled if needed and will include the months of December and January.

The date for the interview will be scheduled only after the IRB committee requests an interview. If no interview is requested, no interview is required.

FEES

Filing Fee for Pre-Approval/Review:	\$ 5 per student
Entry Fee:	\$ 7 per student

Each student submitting his/her paperwork for CTSEF approval before experimentation must pay a \$5 filing fee per student. This covers any number of needed reviews up to final submittal date.

Each student entering the CTSEF must pay a \$7 entry fee. There will be no refunds for any of these fees.

TENTATIVE SCHEDULE OF EVENTS

Tuesday, February 21, 2017

- 8:00 - 10:00 a.m. Registration and exhibit setup - Student Recreation Center
- 9:30 - 11:30 a.m. TSTC Campus Tours
- 10:00 - 12:00 p.m. Display & Safety Committee Inspection, SRC reviews
- 10:00 - 11:30 a.m. Junior Science Bowl – Ideas Center
- 11:30 - 12:30 p.m. Lunch for students - Student Service Center
- 12:30 - 1:30 p.m. SRC appeals - students check for violations
- 1:30 - 3:00 p.m. Junior Science Bowl Finalists
- 2:30 - 4:30 p.m. Bryce C. Brown Award Scholarship and Baylor University - TSTC Student Recreation Center Game Room
- 3:15 - 7:00 p.m. Special Award Judging (students may be present at their projects)
- 4:30 - 5:45 p.m. Dinner for students - Student Services
- 5:00 - 6:15 p.m. Regional Judges' Orientation – TSTC Culinary Arts Dining Room
- 6:00 - 9:00 p.m. REGIONAL JUDGING - All exhibitors must be with their displays, until released
- 6:15 - 7:30 p.m. Teacher/Sponsors Dinner - TSTC Culinary Arts Dining Room

Wednesday, February 22, 2017

- 8:30 - 11:30 a.m. FAIR OPEN TO PUBLIC - TSTC - Student Recreation Center
- 9:00 - 11:00 a.m. **Awards Ceremony- TSTC- John B. Connally Center**
- 11:30 - 1:00 p.m. **Winner's orientation for ISEF & EMSEF - Student Recreation Center**
- 12:00 p.m. Exhibit removal - TSTC Student Recreation Center

-
- Projects placing 1st in each category **MUST** remain on exhibit for 15 minutes following the end of the Awards Ceremony to allow others an opportunity to view the winning projects.
 - No projects will be disassembled before 12:00 p.m. to allow full viewing time by the public.

THE BRYCE C. BROWN AWARD

Each year, in memory of Dr. Bryce C. Brown, the CTSEF founder and Director from 1956–1983, an award is given to the most promising young scientist regardless of age or category. Only ONE STUDENT FROM EACH SCHOOL is eligible to qualify for this award each year. The Nominee must be recommended by his/her school science fair teacher, after demonstrating proficiency and interest in the scientific method.

This award is one of the most prestigious offered by the CTSEF. Nominees should demonstrate both a continuing interest in science or engineering, and intent to pursue a science-related career. The Bryce C. Brown Award will not be awarded more than once to the same student.

Application Procedure:

- The Bryce C. Brown Award application form will be sent with your entry form information in January.
- The Science teacher/sponsor should complete the application form and letter of recommendation, place in one envelope, and mail or deliver it to the Central Texas Science and Engineering Fair office. The application must be in the CTSEF office by February 3, 2017.
- Applications for the Bryce C. Brown Award will be screened by a panel of Baylor faculty and CTSEF Board Members. The applicants will be invited to an interview with the panel during the Regional Science Fair on Tuesday February 22, 2017. The names of students who will be interviewed will be posted on the information board at the TSTC Murray Watson Student Recreation Center at registration.
- The Bryce C. Brown Award recipient will be announced at the annual CTSEF Awards ceremony.

CTSEF BAYLOR UNIVERSITY SCHOLARSHIP

Students in their **junior** or **senior** year of high school who have qualified for entry in any category in the 2017 Central Texas Science and Engineering Fair may apply for the CTSEF Baylor University Scholarship award. The scholarship provides **\$4,000** tuition to Baylor University.

Application Procedure:

- The student should complete the application form and mail or deliver it with two letters of recommendation and a writing sample—all in one envelope—to Central Texas Science and Engineering Fair office. The application and accompanying materials must be in the CTSEF office by February 3, 2017.
- Applications for the scholarship will be screened by a panel of Baylor faculty, and the top three applicants will be invited to an interview with the scholarship selection committee during the Regional Science Fair at TSTC on Tuesday February 22, 2017. The students who will be interviewed will be posted on the information board at the TSTC Murray Watson Student Recreation Center at registration. Time and place of the interview will be included.
- The scholarship recipient will be announced at the annual CTSEF Awards Ceremony which begins at 9:00 a.m. (time may vary), Wednesday, February 22, 2017, at the John B. Connally Center.
- In addition to the information on the application form, the selection committee will consider:
 1. The applicant's academic record in high school.
 2. Recommendations written by his/her Science Fair sponsor and high school principal or counselor.
 3. He/she should demonstrate interest in becoming a Baylor University student.

Scholarship Information:

- The Baylor University Scholarship application form will be sent with your entry form information in January.
- The \$4,000 scholarship is limited to tuition remission only and does not cover books, housing, or fees.
- The student must meet all the qualifications necessary to be accepted into Baylor, must apply for admission to Baylor through regular procedures, must be accepted into Baylor, and must register for Baylor classes before the scholarship goes into effect.
- The student should report receipt of the scholarship in any application for a financial aid package at Baylor University.

The signed application must be accompanied by:

- 1) **Letters of recommendation** from:
 - a. your Science Fair sponsor
 - b. your high school principal or high school counselor

These letters should explain your eligibility for the scholarship based on the above criteria and should include any other information about your qualifications for the award.
- 2) A **writing sample**, in which you explain:
 - a. ways you think participation in the Science Fair program benefits students
 - b. your reasons for wanting to attend Baylor University

The writing sample may be typewritten or neatly handwritten, but it should not exceed one-page in length (if typewritten) and should contain at least 150 words, but not more than 300 words.

Send application, letters of recommendation, and writing sample in one envelope to:

BU Scholarship
Central Texas Science & Engineering Fair
One Bear Place #97356
Waco TX 76798

Deadline: February 03, 2017 by 4:00 p.m.

RULES FOR ALL PARTICIPANTS

- 1) Students must participate, and place 1st, 2nd, or 3rd in one of the 18 categories, in a local fair and meet all the criteria set out in the handbook.
- 2) All CTSEF and ISEF rules and guidelines must be read, understood, and followed.
- 3) To compete in the CTSEF, every student must complete the **Waiver and Release of Liability Form, Student Checklist (1A), Research Plan, and Approval Form (1B)**, and review with his/her teacher or Adult Sponsor as teacher/sponsor completes the **Checklist for Adult Sponsor (1)**.
- 4) Projects must adhere to all Federal, State, and local laws and regulations.
- 5) Students should retain all original forms. Only copies of forms should be submitted for CTSEF approval. These forms will always include at least the **Checklist for Adult Sponsor (1), Student Checklist (1A), Research Plan, and Approval Form (1B)**.
- 6) Certain projects require additional forms and/or specific reviews.
 - A) All projects involving human participants require special procedures.
 - a) An Institutional Review Board (IRB) must review project and approve BEFORE experimentation begins.
 - b) **Human Participants Form (4)** is required for all projects involving human participants. You may need an Informed Consent Form as well. An Informed Consent Form is used to provide information to the research subject (or parent/guardian) and to document written informed consent, minor assent and/or parental permission.
 - c) A copy of any test, survey, or questionnaire must be provided for parental review for subjects less than 18 years of age.
 - d) If a school chooses to have a local Institutional Review Board (IRB) the student must have an interview with that board.
 - e) After the local IRB review board has approved the student's project the student must submit the project to the CTSEF for approval.
 - f) The CTSEF IRB will review all human participants projects and may schedule an interview date.
 - g) If the deficiency form states that changes need to be addressed, the corrections must be made on the students' original paperwork and then re-uploaded to the student's profile online, return the project to review status, by the next deadline time. This must be before the IRB interview (if one is requested).
 - h) If the project corrections, listed on your deficiency form, are not made there will be no other review until you have completed the corrections listed.
 - i) If an IRB interview is requested, the student /teacher/sponsor must email or call the CTSEF office to set an appointment time. The student need to make sure to attend their scheduled interview time and bring a clean corrected copy of the research plan and all forms.
 - B) Experiments that involve vertebrate animals, potentially hazardous biological agents, controlled substances, nonexempt recombinant DNA, certain tissue studies, and all studies involving more than a minimal risk to the researcher, require approval from a Scientific Review Committee (SRC) **before** experimentation begins and must be submitted using the online process (www.ctsef.org) [read **Research Plan instruction sheet**].
 - C) All other projects require a review by the CTSEF Project Review Team and must be submitted online.

- 7) All studies involving vertebrate animals, potentially hazardous biological agents, controlled substances, nonexempt recombinant DNA, certain tissue studies, and all studies involving more than a minimal risk in human participants must have a Designated Supervisor or Qualified Scientist, depending on risk assessment.
- 8) Projects that are continuations of previous years' work and that require IRB/SRC approval must be re-approved prior to experimentation for the current year. Any continuing project must document new or more advanced research.
- 9) **Human and Vertebrate Animal Tissue Form (6B)**, if applicable, must be submitted for SRC review and approval before student begins experimentation.
- 10) The use of alcohol, acid rain, insecticides, herbicides, and heavy metals in toxicity or behavioral studies on live vertebrates is prohibited.
- 11) Studies involving any pathogenic or potentially pathogenic agents are prohibited in a home environment, but specimens may be collected at home.
- 12) Non-invasive (behavioral) studies involving pets and livestock may be done at home.
- 13) **No vertebrate animal deaths** due to the experimental procedures are permitted in any group or subgroup. Such a project will fail to qualify for competition.
- 14) Any proposed changes in the **Research Plan** by the student after initial IRB/SRC approval must have subsequent IRB/SRC approval before experimentation begins/resumes.
- 15) If work was conducted in an institutional or industrial setting any time during the current project year, **Regulated Research Institutional/Industrial Setting Form (1C)** must be completed.
- 16) Use of models alone or demonstrations is not creative and is not allowed.
- 17) Collections should only be used to support an investigation or help to answer a question.
- 18) Display or poster exhibits showing only library research are **not acceptable**. Projects must present the results of experimental investigation or field studies.
- 19) NO product testing is allowed at the Regional Fair level. Although acceptable at the local level, product testing projects may not advance to the CTSEF.
- 20) Each student may enter only **one** project that covers research done over a maximum continuous 12-month period between January of previous fair year and current year fair.
- 21) All exhibits must adhere to CTSEF/ISEF safety and size requirements.
- 22) **It is important that students retain all original signed forms. The only exception is the waiver that is sent with your **FINAL** review and it must be the original **(INK)** signed form.**
- 23) It is the student's responsibility to check with the CTSEF for any additional restrictions or requirements.

ETHICS STATEMENT

Scientific fraud and misconduct are not condoned at any level of research or competition. Plagiarism, use or presentation of other researcher's work as one's own, and fabrication or falsification of data will not be tolerated. Fraudulent projects will fail to qualify for competition in affiliated fairs or the ISEF. All projects must adhere to the Ethics Statement.

LIMITATIONS

1. Each student may enter only one project, which covers research done over a maximum continuous 12-month period between January 2016 and May 2017.
2. Students may compete in only one ISEF Affiliated Fair, except when proceeding to a state/national fair affiliated with the Intel ISEF from an affiliated regional fair.
3. Any student in grades 9-12 or equivalent is eligible, none of whom having reached the age of 21 on or before May 1 preceding the Intel ISEF.

CONTINUATION OF PROJECTS

1. **Students will** be judged only on the most recent year's research. Display boards must reflect the current year's work only. However, supporting data books (not research papers) from previous related research may be exhibited on the table, properly labeled as such. The project title displayed in the participant's area may mention years (for example, "Year Two of an Ongoing Study"). This project year includes research conducted over a maximum of 12 continuous months from January of one year to May the following year. Any continuing project must document new and different research (e.g. testing new variables or new line of investigation, etc.). Repetition of previous experimentation or increasing sample sizes are examples of unacceptable continuations.
2. **Longitudinal studied are permitted as an acceptable continuation under the following conditions:**
 - a) The study is a multi-year study testing or documenting the same variables in which time is the critical variable. Examples: Effect of high rain or drought on soil in a given basin or return of flora and fauna in a burned period over time.)
 - b) Each consecutive year must demonstrate time-based changes.
 - c) The display board must be based on collective past conclusionary data and its comparison to the current year data set. No raw data from previous years may be displayed.
3. Complete the **Continuation Projects Form (7)**. Documentation must include the **previous year's abstract** and **research plan** and the abstract for all other prior years. Copies must be attached behind the current year's **research plan** and forms. Each page of prior work must be clearly labeled in the upper right corner with the years (ex 2014-2015). Retain all previous years' paperwork in case an SRC requests documentation of experimentation conducted in prior years.
4. A copy of the completed Form 7 must be **vertically displayed** at your project.

TEAM PROJECTS

1. Only the 1st, 2nd, and 3rd place team winners may enter the CTSEF from the junior division and senior division. Team projects compete in a separate “team” category against all other team projects per division. The CTSEF has the option of sending a team project, in addition to two individual projects, to the Intel ISEF. Team project entries are not required.
2. Teams may have up to three (3) members. **NOTE:** Teams may not have more than three members at a local fair and then eliminate members to qualify for the CTSEF.
3. Team membership cannot be changed during a given research year, including converting from an individual project or vice versa, but may altered in subsequent years.
4. Each team should appoint a team leader to coordinate the work and act as a spokesperson. However, each member of the team should be able to serve as spokesperson, be fully involved with the project, and be familiar with all aspects of the project. The final work should reflect the coordinated efforts of all team members and will be evaluated using the same rules and judging criteria as individual projects.
5. Each team member must submit an **Approval Form (1B)**. However, team members must jointly submit one **Checklist for Adult Sponsor (1)**, **one abstract**, a **Research Plan (1A)** with all team member names, and other required forms.
6. Full names of all team members must appear on the Abstract and all forms that require them.

DEFICIENCY FORMS EXPLANATION

1. A Deficiency Form from one of the review committees will be returned to the student's profile page.
2. The Deficiency Form check boxes and comments **MUST** always be corrected and returned to the CTSEF online process for additional reviews until the online process is complete. Once the online process is completed you will receive instructions for the final approval and the appropriate committee chairperson's signature.
3. Comments are numbered for each review. Each of these items must be addressed and corrected on your **original** paperwork. Please note that there may be additional notes in the lower comment section. Please read the complete review and correct all items.
4. The following is an explanation of the Pre-Approval Status Box for the PRT, SRC, or IRB:
 1. Approved –
 - a) suggestions only for a better project may be made, but changes are not required.
 - b) project paperwork need not be returned until entry date, once project is stamped approved.
 - c) research may begin - this project is approved for experimentation to begin.
 - d) once approved, your project will be returned with the word APPROVED stamped in the upper right hand corner of the Checklist for Adult Spons or (1) form.
 2. Online Process Complete –
 - a) make a copy of your online process paperwork.
 - b) remember to check all forms.
 - c) mail or bring the complete copy (not the ink signed original) to the CTSEF office for final review.
 - d) your copy of your completed paperwork will be returned to you once your project has final approval and then, and only then, may your experiment begin (approved stamped and CTSEF signed).
 3. Incomplete/Resubmit –
 - a) items checked must be corrected as well as any comments listed in the comments.
 - b) return all corrected paperwork online by the next review date.
 - c) the committee must review and approve your project before experimentation may begin.
 4. Not Approved for Entry –
 - a) demonstration only.
 - b) library research only.
 - c) report only.
 - d) product testing or comparisons.
 5. **New IRB Review Changes** –
 - a) IRB Research Proposal needs correction. Read project review, make corrections, and resubmit. IRB forms are reviewed after Research Proposal is online complete.
 - b) IRB Research Proposal **ONLY** is online complete. Forms are reviewed separately and **MUST** also be online complete.
 - c) IRB Forms need correction. Read project review, make corrections, and resubmit.
 - d) Both the Research Plan and IRB Forms are online complete. Experimentation **CANNOT** begin until you have obtained the following required signatures from the CTSEF Review Committee (read instructions).

NOTE: ALL projects require a research notebook.

Common problems seen by SRC (what not to do): See: www.societyforscience.org/isef/rules.asp

SCIENTIFIC REVIEW COMMITTEE (SRC) & PROJECT REVIEW TEAM (PRT)

The purpose of the SRC and PRT is to qualify a student researcher to enter the CTSEF. The committees are made up of a group of adults knowledgeable about regulations concerning experimentation in restricted and non-restricted areas. They review and approve experimental procedures to make sure they comply with the Rules and any pertinent laws.

The SRC consists of a minimum of:

- a) a biomedical scientist (Ph.D., M.D., D.V.M., D.D.S., or D.O.)
- b) a science teacher
- c) at least one other member

The PRT consists of scientists in:

- a) chemistry
- b) biology
- c) biophysics
- d) engineering
- e) computer science

The SRC and PRT examine projects for the following:

- a) evidence of library research
- b) evidence of proper supervision
- c) use of accepted research techniques
- d) completed forms, signature, and dates
- e) appropriate documents and substantial expansion for continuation projects
- f) compliance with the ISEF ethics statement

The SRC **further** examines projects for:

- a) evidence of search for alternatives to animal use
- b) humane treatment of animals
- c) compliance with rules and laws governing human and animal research
- d) compliance with rules regarding potentially hazardous biological agents, controlled substances and hazardous substances and devices

It is important that students retain all original signed forms. Original signed forms should never be sent to a higher level of competition.

The SRC follows this two-step process:

- 1) **BEFORE EXPERIMENTATION**, the SRC reviews and approves experimental procedures for projects involving Human Participants, nonhuman vertebrates, pathogenic agents, controlled substances, recombinant DNA, and human/animal tissue to make sure that they comply with the Rules and any pertinent laws. Human studies reviewed and approved by a properly constituted IRB must be reviewed by the SRC before beginning research.
- 2) **AFTER EXPERIMENTATION AND SHORTLY BEFORE THE CTSEF FAIR**, the SRC reviews and approves those same projects to make sure that students followed the approved **Research Plan** and the Rules.

The PRT follows this two-step process:

- 1) **BEFORE EXPERIMENTATION**, the PRT reviews all projects not requiring SRC approval. They ensure that the student is following all rules necessary for their area of research.
- 2) **AFTER EXPERIMENTATION AND SHORTLY BEFORE THE CTSEF FAIR**, the PRT reviews and approves those same projects to make sure that students followed the approved **Research Plan** and the Rules. The PRT reviews all projects not requiring prior SRC or IRB approval.

INSTITUTIONAL REVIEW BOARD (IRB)

An Institutional Review Board (IRB) is a committee that, according to federal law, **must evaluate the potential physical or psychological risk of research involving Human Participants**. All proposed human research must be reviewed and approved by a proper IRB before experimentation begins. This includes review of any videos, music, games, surveys or questionnaires to be used in a project.

An IRB at the school or the CTSEF must consist of a minimum of three members. Additional members are recommended to avoid conflict of interest. The IRB should include:

- a) an educator,
- b) a school administrator (preferably, a principal or vice principal),
- c) and one or more of the following: a psychologist, psychiatrist, medical doctor, physician's assistant, or registered nurse or licensed social worker.
- d) When the project concerns behavioral research, the IRB must include a psychologist or psychiatrist. (Federal law 25-CFR-46.)

Due to the federal regulations requiring local community involvement, an IRB should be established at the school level to deal with human research projects. If it is impossible to establish an IRB at each school, the teacher/school should contact the CTSEF IRB for assistance in evaluating human research prior to experimentation.

- 1) Institutional Review Boards (IRBs) exist at federally registered research institutions. For research not performed at one of these facilities, the sponsoring research organization (high school, local, or affiliated fair, etc.) must appoint an IRB to review and approve any proposed research involving Human Participants.
- 2) **An IRB generally makes the final determination of risk. However, if the SRC rules an IRB's decision as inappropriate, thereby placing Human Participants in jeopardy, the SRC may override the IRB's decision and the project may fail to qualify for competition.**
- 3) A school-established IRB must register its members with the CTSEF.
- 4) The chair of the school IRB must attend a workshop sponsored by the CTSEF.
- 5) **If the project is behavioral, a psychologist, psychiatrist, or individual with human behavioral training* must serve on the IRB.**
- 6) **For subjects under 18, student researchers must obtain written informed consent from all subjects and their parent/guardian when more than minimum risk is involved.**
- 7) **Neither the Adult Sponsor, parents, nor the Qualified Scientist who oversees a specific project is permitted to serve on the SRC or IRB reviewing that project. Consequently, neither the Adult Sponsor nor the Qualified Scientist may sign the SRC/IRB portion of Approval Form (1B). This eliminates conflict of interest.**

*Human behavioral training (i.e. RN has to undergo course work plus training in an institutional setting such as a state psychiatric hospital).

ADDITIONAL CTSEF HUMAN PARTICIPANTS GUIDELINES

Pre-collegiate researchers conducting human experiments using movies, video games, videos, music lyrics, surveys, questionnaires, pictures, photographs, drawings, or printed advertisements must adhere to the following guidelines:

1. Movies - limited to these ratings: G, PG, or PG-13. Those movies rated PG-13 must be reviewed and approved by the parents of subjects under 18 years old. The researcher must present parents' documentation of the viewing and written approval for each subject.
2. Video games - can only include the following industry rated categories: EC, E, and E10+. Those video games rated E10+ must be reviewed and approved by parents of subjects under 18 years old. The researcher must present parents' documentation of the viewing and written approval for each subject.
3. Videos - all other videos not included in the categories listed above under #1 or #2, must be reviewed by the CTSEF IRB before approval. This includes music videos, home videos, YouTube videos, etc. NO EXCEPTIONS!
4. Music - recorded or printed lyrics must be reviewed by the CTSEF IRB and approved. Lyrics with references to profanity, sexuality/sexual behavior, violence, alcohol or drug use, weapons, or human injury or death, will not be approved.
5. Visual images - pictures, photographs, drawings, advertisements, etc., must be reviewed and approved by the CTSEF IRB before experimentation may begin. Any visual images portraying sexual behavior, violence, alcohol or drug use, weapons, human injury or death, or derogatory behaviors will not be approved.
6. Surveys and questionnaires - copies must be submitted to the CTSEF IRB for review and approval. Any that expose the subject to emotionally distressing questions, materials or activities will not be approved.
7. Ingestion Projects - a detailed explanation is required to explain why the participant is to ingest the item. All safety procedures must be included with the explanation.

The CTSEF IRB will make every effort to help you develop an acceptable project. However, research designs that propose one or more of the above risk categories may be difficult or impossible to get approved.

All IRB projects MUST be approved by the CTSEF Review committee before experimentation may begin.

DISPLAY AND SAFETY REGULATIONS

Not Allowed at Project

- 1) Living organisms including plants.
- 2) No soil, sand, rock, and/or waste samples
- 3) Taxidermy specimens or parts.
- 4) Preserved vertebrate or invertebrate animals.
- 5) Human or animal food.
- 6) Human/animal parts or body fluids (for example, blood, and urine) (Exceptions: teeth, hair, nails)
- 7) Plant materials (living, dead, or preserved) in their raw, unprocessed, or non-manufactured state (Exception: manufactured construction materials used in building the project or display)
- 8) Laboratory/household chemicals including water (projects may not use water in any form in a demonstration)
- 9) Poisons, drugs, controlled substances, hazardous substances or devices (for example, firearms, weapons, ammunition, reloading devices)
- 10) Dry ice or other sublimating solids
- 11) Sharp items (for example, syringes, needles, pipettes, and knives)
- 12) Flames or highly flammable materials
- 13) Batteries with open-top cells
- 14) Awards, medals, business cards, flags, endorsements and/or acknowledgments (graphic or written)
- 15) Photographs or other visual presentations depicting vertebrate animals in surgical techniques, dissections, necropsies, other lab techniques, improper handling methods, improper housing conditions, etc.
- 16) Active Internet or e-mail connections as part of displaying or operation of the project at the CTSEF.
- 17) Prior years' written material or visual depictions on the vertical display board. [Exception: the project title displayed in the finalist's booth may mention years or which year the project is (for example, "Year Two of an Ongoing Study"). Continuation projects must have the Continuation Project Form (7) vertically displayed.
- 18) Glass or glass objects unless deemed by the Display and Safety Committee to be an integral and necessary part of the project (Exception: glass that is an integral part of a commercial product such as a computer screen)
- 19) Any apparatus deemed unsafe by the Scientific Review Committee, the Display and Safety Committee, or Science Service (for example, large vacuum tubes or dangerous ray-generating devices, empty tanks that previously contained combustible liquids or gases, pressurized tanks, etc.)

Allowed at Project with the Restrictions Indicated

- 1) Empty tanks that previously contained combustible liquids or gases must be certified as having been purged with carbon dioxide.
- 2) Accomplishments, acknowledgments, addresses other than the student's addresses, telephone and FAX numbers, and e-mail and World Wide Web addresses, are allowed only inside research papers or data books.
- 3) Photographs and/or visual depictions if:
 - a) They are not deemed offensive or inappropriate by the Scientific Review Committee, the Display and Safety Committee, or Science Service.
 - b) Credit lines of their origins ("Photograph taken by..." or "Image taken from...") are attached. (If all photographs being displayed were taken by the participant or are from the same source, one credit line prominently displayed is sufficient)
 - c) They are from the internet, magazines, newspapers, journals, etc., and credit lines are attached. (If all photographs/images are from the same source, one credit prominently displayed is sufficient.)
 - d) They are photographs or visual depictions of the Finalist.
 - e) They are photographs of Human Participants for which signed consent forms are at the project. (Human Participants Form 4 or equivalent photo release signed by the human subject must be included in paperwork and properly checked on the Official Abstract and Certification).
- 4) Any apparatus with unshielded belts, pulleys, chains, or moving parts with tension or pinch points if for **display only and may not be operated**.

- 5) Class II lasers if:
 - a) The output energy is <1 mW and is operated only by the finalist.
 - b) Operated only during Display and Safety inspection and during judging.
 - c.) Labeled with a sign reading "Laser Radiation: Do Not Stare into Beam."
 - d) **Enclosed in protective housing** that prevents physical and visual access to beam.
 - e) **Disconnected** when not operating.
- 6) Class III and IV lasers **if for display only and not operated**.
- 7) Any apparatus producing temperatures that will cause physical burns must be adequately insulated.

Electrical Regulations at the CTSEF

- 1) Entrants requiring 120 or 220 Volt A.C. electrical circuits must provide a UL-listed 3-wire extension cord that is appropriate for the load and equipment.
- 2) Electrical power supplied to projects and, therefore, the maximums allowed for projects is 120 or 220 Volt, A.C., single phase, 60 cycle. Maximum circuit amperage/voltage available is determined by the electrical circuit capacities of the exhibit hall and may be adjusted on-site by the Display and Safety Committee. For all electrical regulations, "120 Volt A.C." or "220 Volt A.C." is intended to encompass the corresponding range of voltage as supplied by the facility in which the Intel ISEF is being held.
- 3) All electrical work must conform to the *National Electrical Code* or exhibit hall regulations. The guidelines presented here are general ones, and other rules may apply to specific configurations. The on-site electrician may be requested to review electrical work on any project.
- 4) All electrical connectors, wiring, switches, extension cords, fuses, etc. must be UL-listed and must be appropriate for the load and equipment. Connections must be soldered or made with UL-listed connectors. Wiring, switches, and metal parts must have adequate insulation and overcurrent safety devices (such as fuses) and must be inaccessible to anyone but the Finalist. Exposed electrical equipment or metal that is liable to be energized must be grounded or shielded with a non-conducting material or with a grounded metal box or cage to prevent accidental contact.
- 5) Wiring which is not part of a commercially available UL-listed appliance or piece of equipment must have a fuse or circuit breaker on the supply side of the power source and prior to any project equipment.
- 6) There must be an accessible, clearly visible on/off switch or other means of disconnect from the 120- or 220-volt power source.
- 7) Any lighting that generates considerable and excessive amounts of heat (high-intensity lamps, certain halogen lights etc.) must be turned off when the Finalist is not present.

Items Required at Display

- 1) Abstract must be vertical on or at the display board.
- 2) Scientific Review Committee approval form (received on site at the CTSEF) – yellow quarter sheet.
- 3) Forms which must be with sponsor, but not on display:
 - a) Form 4 is required for Human Participants projects.
 - b) Informed Consent Form is used to provide information to the research subject (or parent/guardian) and to document written informed consent, minor assent and or parental permission. It is also for any identifiable and/or recognizable people (except the entrant or entrant's family members) who are included in any photographs or visual depictions anywhere at the project (See #4 under Allowed at Project with the Restrictions Indicated, this page).
- 4) Other forms [including, but not limited to, Checklist for Adult Sponsor (1), Students Checklist (1A), Research Plan and Approval Form (1B)] which are required for the project or for SRC approval.
- 5) Projects requiring form 1C must display a copy vertically on display board.
- 6) Photo/image credits

ENTRY RULES

- 1) All projects must be entered on an Official Entry Form in order to compete at the CTSEF.
- 2) No project that uses forms different from those included in the handbook or different from the CTSEF website will be accepted. The current year forms must be used.
- 3) Each exhibitor must furnish all information requested on the entry form, including all signatures. Failure to do so may result in an application not being processed for entry.
- 4) All CTSEF-approved forms, a copy of the abstract, and a \$7 entry fee per student must be included with the Official Entry Form.
- 5) The abstract must be a one-page summary of the current year's work only on the ISEF official form. It must describe research conducted by the student, not by adult supervisors. The abstract can have a maximum of 250 words.
- 6) Each student's (or team's) paperwork should be stapled in numerical order.
- 7) Students with projects that are a continuation of previous year's research must submit all prior year's abstracts and research plans, properly labeled, at entry deadline.
- 8) Entry paperwork must be submitted to the CTSEF office in person or by mail by the entry deadline on **Friday, February 3, 2017**. LATE APPLICANTS WILL NOT BE ACCEPTED FOR ENTRY.
- 9) Carefully check the entry form for accuracy before submitting it to the CTSEF office. No last-minute changes will be made on the day of the fair if inaccurate information was given on the entry form.
- 10) Applications for the Baylor University Scholarship Award and the Bryce C. Brown Award for the Most Promising Young Scientist must be submitted to the CTSEF office by the entry deadline.
- 11) Entry fees will not be refunded if a student fails to attend the CTSEF. No exceptions.
- 12) **It is important that students retain all original signed forms.** Even though copies of paperwork are sent with the entry form, students must bring original signed forms to the CTSEF in case an SRC interview is necessary.

JUDGING RULES

- 1) The senior division (grades 9-12) will be judged separately from the junior division (grades 6-8). Team projects will be set up in the team category and will be judged either in team grades 9-12 (senior) or team category grades 6-8 (junior). Competition will be as a team category, regardless of type of research emphasis.
- 2) During judging the exhibition area will be closed to all except student entrants, judges, and CTSEF officials.
- 3) All exhibitors must be present and remain with their exhibits during the regular judging time. Students may not leave their exhibits until released by CTSEF officials. Plan on a late night.
- 4) All exhibits must be approved by the Scientific Review Committee, and the Display and Safety Committee. A signed approval card must be displayed at the exhibit before it will be judged.
- 5) In any case involving a question of judging, eligibility or any other aspect of the Central Texas Science and Engineering Fair, the decision of the CTSEF Director and the Scientific Review Committee will be final.

STUDENT CHECKLIST

1. **READ** ISEF Rules and Guideline thoroughly and carefully, paying special attention to the sections entitled: Student Guidelines, Rules for All Participants, Display and Safety Regulations, and Entry Rules.
2. Using the Student Guidelines section as a roadmap, start to **THINK** about research that may interest you. Talk to your teacher/adult sponsor concerning your project. Remember that all projects need approval before experimentation can begin.
3. **SUBMIT** all required paperwork by pre-approval deadline online through Scienteer.com at: www.ctsef.org
 - **Waiver and Release of Liability Form** (found online at: www.ctsef.org) must be completed in order for CTSEF office to process your paperwork. This form must be sent to the CTSEF office after your online process is complete with your final approval paperwork.
 - **Form 1** – Checklist for Adult Sponsor.
 - **Form 1A** – Student Checklist. Remember that experimentation cannot begin until all forms have been read and approved by CTSEF.
 - **Research Plan** – This document will include your problem statement, your hypothesis, your materials list, your procedure for testing the hypothesis, and the sources of your research (bibliography). Remember, be consistent with the format you choose for your bibliography, and write your procedure in step-by-step format so it can be repeated by someone else.
 - **Form 1B** – Approval Form. This form requires several signatures. Be certain that you allow enough time to complete your research!
 - There may be various **other forms** that must be completed and signed as required by your particular type of project. Refer to the international rules book to determine your type of project and the necessary forms needed to satisfy the requirements.
 - \$5 filing fee per student for pre-approval review. For all research projects, the research plan and all applicable forms must be completed online and the \$5 filing fee sent to the CTSEF office for each student before the pre-approval deadline (See Important Dates and Deadlines in Section 2). The mailing address to the CTSEF office is: CTSEF Baylor University, One Bear Place #97356, Waco, TX 76798.
 - **All IRB** projects involving Human Participants might require an interview. **Interviews will only be held as requested by the IRB committee chairperson and will not be charged an additional fee.**
 - \$10 per project for **regional SRC interview**. This fee is **optional** and applies only if a student wishes to have a regional SRC interview for his/her proposed research.

ALL PAPERWORK AND FORMS MUST BE SUBMITTED IN NUMERICAL ORDER

4. **CORRECT** deficiencies and **RESUBMIT** by correction deadline: (See Important Dates and Deadlines) or as soon as corrections are made.
 - A Deficiency Form with suggestions and /or corrections will be returned to you with your paperwork online.
 - The student must correct the deficiencies and the teacher/sponsor must check each correction. Deficiencies require that paperwork be returned online until online process is complete by CTSEF.
 - **A student's project is approved to begin experimentation when the CTSEF committee chairperson has signed the student's Approval Form (1B) and stamped "APPROVED" on the front of the paperwork (final review).**
5. **PERFORM YOUR EXPERIMENT AND GATHER DATA** according to the approved procedure in your research plan.
6. **SUBMIT ENTRY FORM AND OTHER REQUIRED FORMS BY ENTRY DEADLINE**
(See Important Dates and Deadlines).
 - Official Entry Form – All entries must be submitted on current year Official Entry Form in order to compete at the CTSEF. Failure to properly complete the Entry Form, including all signatures, may result in disqualification.
 - **Copies of all required forms, a copy of the abstract, and entry fee must be included with the Entry Form.**
 - Each student's (or team of student's) paperwork must be stapled in numerical order.
 - Continuation of previous year's (s) research must include all previous dated abstracts and research plans as attachments, properly labeled, at the back of the current year's paperwork.
 - No last-minute changes will be made at the fair for inaccurate information submitted on forms.
 - **LATE APPLICANTS WILL NOT BE ACCEPTED FOR ENTRY!**
 - **Entry fees will not be refunded** if a student fails to attend the CTSEF. No exceptions.
 - \$7 entry fee per student
7. **REGISTER** at the Student Recreation Center on the TSTC campus at announced time and date.
8. Your **Project Data Notebook** must be at your project along with a copy of your completed paperwork.
9. **PLAN** for late judging. Dismissal of students should be no later than 10:00 p.m.
10. **ATTEND** the Awards Ceremony the next morning. (Awards ceremony times may change.)

STUDENT GUIDELINES FOR SCIENCE FAIR

Science Research and the Process of Science

Research is the process by which people discover or create new knowledge about the world in which they live. The Affiliated Fairs are research (data) driven. Students design research projects that provide quantitative data through experimentation followed by analysis and application of the data. Projects that are demonstration “library” research or informational projects, “explanation” models or kit building are not appropriate for research based science fairs. When choosing your topic, give careful thought to how your research might enhance the world and its inhabitants.

Questioning is probably the most important part of scientific creativity and is often followed by an “if...then” statement. Students are encouraged to design “controlled” experiments, ones that allow them to set up a standard and then change only one variable at a time to see how that variable might affect the original condition tested as the standard. Thus, questioning usually leads to experiments or observations.

Good scientists, both young and old, use a process to study what they see in the world. The process has been referred as the “Scientific Method” or more recently as the “Inquiry Cycle”. From the following stages you should be able to produce a superior scientific experiment:

- 1) Be curious, choose a limited subject, ask a question; identify or originate/define a problem. It is important that this question be a ‘testable’ question – one in which data is taken and used to find the answer. A testable question can further be identified as one in which one or more variables can be identified and tested to see the impact of that variable on the original set of conditions. The question should not merely be ‘information’ question where the answer is obtainable through literature research.
- 2) Review published materials related to your problem or question. This is called background research.
- 3) Evaluate possible solutions and guess why you think it will happen (hypothesis).
- 4) Experimental design (procedure). In designing the experiment, it is critical that only one variable – a condition that may affect the results of the experiment – is changed at a time. This makes the experiment a ‘controlled’ experiment.
- 5) Challenge and test your hypothesis through your procedure of experimentation (data collection) and analysis of your data. Use graphs to help see patterns in the data.
- 6) Draw conclusions based on empirical evidence from the experiment.
- 7) Prepare your report and exhibit.
- 8) Review and discuss the findings with peer group/ professional scientists
- 9) New question(s) may arise from your discussions.

This sets the stage for another research project as new questions are raised from others and the process repeats itself. The hypothesis often changes during the course of the experiment. Supporting or not supporting your hypothesis is secondary to what is learned and discovered during the research.

Students should learn to be skeptical of all research results, especially their own. A good experiment may or may not answer the questions asked, but almost always leads to fresh questions requiring new experiments or observations. The final hypothesis is often developed after one has run a number of preliminary experiments, analyzed a body of results, and reached a tentative conclusion.

All projects need approval prior to experimentation. All projects require the **Waiver and Release of Liability, Checklist for Adult Sponsor, Student Checklist (1A), Research Plan, Approval Form (1B)**, and an **abstract**. To confirm paperwork needed prior to experimentation, refer the ISEF Rules and Guideline www.societyforscience.org/isef.

Non-Inquiry Based Research

Not all areas of study are best served by scientific methods based research. Because engineers, inventors, mathematicians, theoretical physicists, and computer programmers have different objectives than those of other scientists, they follow a different process in their work. The process and that they use to answer a question or solve a problem is different depending on their area of study. Each one uses their own criteria to arrive at a solution.

Engineering Projects

“Scientists try to understand how nature works; engineers create things that never were.” An engineering project should state the engineering goals, the development process and the evaluation of improvements. Engineering projects may include the following:

- 1) Define a need or “How can I make this better?”
- 2) Develop or establish design criteria (could be more than one)
- 3) Do background research and search the literature to see what has already been done or what products already exist that fill a similar need. What make them good and what makes them weak?
- 4) Prepare preliminary designs and a materials list. Consider costs, manufacturing and user requirements.
- 5) Build and test a prototype of your best design. Consider reliability, repair and servicing.
- 6) Retest and redesign as necessary.
- 7) Present results.

Computer Science Projects

These often involve creating and writing new algorithms to solve a problem or improve on an existing algorithm. Simulations, models or ‘virtual reality’ are other areas on which to conduct research.

Mathematics Projects

These involve proofs, solving equations, etc. Math is the language of science and is used to explain existing phenomena or prove new concepts and ideas.

Theoretical Projects

These projects may involve a thought experiment, development of new theories and explanations, concept formation or designing a mathematical model.

Getting Started

- 1) **Pick Your Topic.** Get an idea of what you want to study. Ideas might come from hobbies or problems you see that need solutions. Due to limited time and resources, you may want to study only one or two specific events.
- 2) **Research Your Topic.** Go to the library or internet and learn everything you can on your topic. Observe related events. Gather existing information your topic. Look for unexplained or unexpected results. Also, talk to professionals in the field, write or email the companies for specific information, and obtain or construct needed equipment.
- 3) **Organize.** Organize everything you have learned about your topic. At this point you should narrow your hypothesis by focusing on a particular idea. Your library research should help you.
- 4) **Make a Timetable.** Choose a topic that not only interests you, but also can be done in the amount of time you have. Use a calendar to identify important dates. Leave time to fill out the forms and to review the Research Plan with your Sponsor. Certain projects require more time because they need prior SRC or IRB approval. Allow plenty of time to experiment and collect data – even simple experiments do not always go as you might expect the first time or even the second time. Also leave time to write a paper and put together an exhibit.
- 5) **Plan Your Experiments.** Once you have a feasible project idea, write a research plan. This plan should explain how you will do your experiments and exactly what it will involve. All students participating in the CTSEF are required to complete the **Waiver and Release of Liability, Checklist for Adult Sponsor, Student Checklist (1A), Research Plan, and Approval Form (1B).**
- 6) **Consult Your Teacher or Adult Sponsor.** You are required to discuss your research plan with a Teacher or an Adult Sponsor and obtain a signature of approval. In reviewing **Student Checklist (1A) with Research Plan**, your Sponsor should determine if additional forms and/or IRB/SRC prior approval is needed.
- 7) **Conduct Your Experiments.** Give careful thought to experimental design. During experimentation, keep detailed notes of each and every experiment, measurement, and observation. Do not rely on your memory. Remember to change only one variable at a

time when experimenting, and make sure to include control experiments in which none of the variables are changed. Make sure you include sufficient numbers of test subjects in both control and experimental groups. A group must have five or more subjects to be statistically valid.

- 8) **Analyze Your Results:** When you complete your experiments, examine and organize your findings. Use appropriate graphs to make ‘pictures’ of your data. Identify patterns from the graphs. This will help you answer your testable question. Did your experiments give you the expected results? Why or why not? Was your experiment performed with the exact same steps each time? Are there other explanations that you had not considered or observed? Were there experimental errors in your data taking, experimental design or observations? Remember, that understanding errors is a key skill scientists must develop. In addition, reporting that a suspected variable did not change the results can be valuable information. That is just as much a ‘discovery’ as if there was some change due to the variable. In addition, statistically analyze your data using the statistics that you can understand and explain their meaning.
- 9) **Draw Conclusions:** Did the variable(s) tested cause a change when compared to the standard you are using? What patterns do you see from your graph analysis that exist between your variables? Which variables are important? Did you collect enough data? Do you need to conduct more experimentation? Keep an open mind – never alter results to fit a theory. If your results do not support your hypothesis, that’s ok and in some cases good! Try to explain why you obtained different results than your literature research predicted for you. Were there sources of error that may have caused these differences? If so, identify them. Even if the results do differ, you still have accomplished successful scientific research because you have taken a question and attempted to discover the answer through quantitative testing. This is the way knowledge is obtained in the world of science. Think of practical applications that can be made from this research. How could this project be used in the real world? Finally, explain how you would improve the experiment and what would you do differently.

Elements of a Successful Project

1) PROJECT DATA BOOK

A project data book is your most treasured piece of work. Accurate and detailed notes make a logical and winning project. Good notes show consistency and thoroughness to the judges, and will help you when writing your research paper. Data tables are also helpful. They may be a little “messy” but be sure the quantitative data recorded is accurate and that units are included in the data tables. Make sure you date each entry.

2) RESEARCH PAPER (OPTIONAL)

A research paper should be prepared and available along with a project data book, and any necessary forms or relevant written materials. A research paper helps organize data as well as thoughts. A good paper includes the following sections:

- a) **Title Page.** Title of your project, division, and classification.
- b) **Table of Contents.** Include a page number for the beginning of each section.
- c) **Introduction.** The introduction sets the scene for your report. The introduction includes your hypothesis, an explanation of what prompted your research, and what you hoped to achieve.
- d) **Materials & Methods (Experiment).** Describe in detail the methodology used to collect your data or make your observations. Your report should be detailed enough so that someone would be able to repeat the experiment from the information in your paper. Include detailed photographs or drawings of self-designed equipment. Only include this year's work.
- e) **Discussion.** The discussion is the essence of your paper. The results and conclusions should flow smoothly and logically from your data. Be thorough. Allow your readers to see your train of thought, letting them know exactly what you did. Compare your results with theoretical values, published data, commonly held beliefs, and/or expected results. Include a discussion of possible errors. How did the data vary between repeated observations of similar events? How were your results affected by uncontrolled events? What would you do differently if you repeated this project? What other experiments should be conducted?
- f) **Conclusion.** Briefly summarize your results. Be specific; do not generalize. Never introduce anything in the conclusion that has not already been discussed.
- g) **Acknowledgments.** You should always credit those who assisted you, including individuals, businesses, and educational or research institutions. Identify any financial support or material donations received, but do not put on display board.
- h) **References/Bibliography:** Your reference list should include any documentation that is not your own (i.e. books, journal articles, websites, etc.). See an appropriate reference in your discipline for format.

For instance, **APA style:**

- 1) **Journal article, one author –**
Bekerian, D.D. (1993), In Search of the Typical Eyewitness. *American Psychologist*, 48. 574-576.
- 2) **Reference to an entire book –**
Cone, J.D., & Forster, S.L. (1993). *Dissertations and Theses from Start to Finish: Psychology and Related Fields*. Washington, DC: American Psychological Association.

Below MLA Format. Bibliography is alphabetical and not numbered. First line is at the margin and the second line of same reference is indented.

Article from a magazine
SPIRAL STRUCTURE, DUST CLOUDS, AND STAR FORMATIONS. Frank H. Shu in *American Scientist*, Vol. 61, pages 524-536; 1973.

Book with an author
THE LARGE-SCALE STRUCTURE OF THE UNIVERSE. J.P.E. Peebles. Princeton University Press, 1980.

Book with an editor
INTERSTELLAR MOLECULES. Edited by B.H. Andrew. D. Reidel Publishing Company, 1980.

Online website
Planning for College and Academic Planning. The College Board. 7 June 2000.
<http://www.collegeboard.org/features/parentqd/html/academic.html>

3) ABSTRACT

After finishing research and experimentation, you are required to write a (maximum) 250-word, one-page abstract. An abstract should include the (a) purpose of the experiment, (b) procedures used, (c) data, and (d) conclusions. It also may include any possible research applications. Only minimal reference to previous work may be included. The abstract should focus on work done since the last fair and should not include: a) acknowledgments, or b) work on procedures done by the mentor. The abstract must be vertically displayed on the project board or in a frame in front of the project board. A copy of your abstract must be included with your paperwork submitted for entry and must be on ISEF required form. The only abstract allowed anywhere at a project is the official abstract (ISEF). The term "abstract" may not be used as a title or reference for any information on an entry display or on materials at the project except as part of the official abstract.

4) VISUAL DISPLAY

You want to attract and inform. Make it easy for interested spectators and judges to assess your study and the results you have obtained. Make the most of your space using clear and concise displays. Make headings stand out, and draw graphs and diagrams clearly and label them correctly. Leave your glassware and chemicals at home. Please make sure to reference the Display and Safety Rules in this book; this information is also available on the Society for Science & the Public website at:
www.societyforscience.org/isef

Helpful Hints for Display:

- Make sure the display reflects the current year's work only.
- A Good Title.** Your title is an extremely important attention-grabber. A good title should simply and accurately present your research. The title should make the casual observer want to know more.
- Take Photographs.** Many projects involve elements that may not be safely exhibited at the fair, but are an important part of the project. You might want to take photographs of important parts/phases of your experiment to use in your display. Photographs or other visual images of human test subjects must have informed consent (Form 4) please read page 21 of the Intel International Rules (ISEF guidelines 2012).
- Be Organized.** Make sure your display is logically presented and easy to read. A glance should permit anyone (particularly the judges) to locate quickly the title, experiments, results, and conclusions. When you arrange your display, imagine that you are seeing it for the first time.
- Eye-Catching.** Make your display stand out. Use neat, colorful headings, charts, and graphs to present your project. Home-built equipment, construction paper, and colored markers are excellent for project displays. Pay special attention to the labeling of graphs, charts, diagrams, and tables. Each item must have a descriptive title. Anyone should be able to understand the visuals without further explanation.
- Correctly Presented and Well-Constructed.** Be sure to adhere to the size limitations and safety rules when preparing your display. Display all required forms for your project. Make sure your display is sturdy, as it will need to remain intact for quite a while. Do not hesitate to ask for advice from adults as needed.

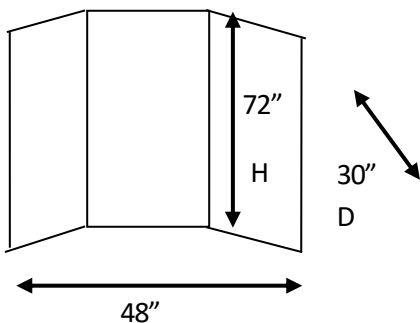

30" deep
48" wide
72" high
(does not include table height)

Judges

- Judges evaluate and focus on 1) what the student did in the current year; 2) how well a student followed the scientific methodologies; 3) the detail and accuracy of research as documented in the data book; and 4) whether experimental procedures were used in the best possible way.

- Judges look for well thought-out research. They look at how significant your project is in its field, as well as how thorough you were. Did you leave something out? Did you start with four experiments and finish only three?
- Judges applaud those students who can speak freely and confidently about their work. They are not interested in memorized speeches – they simply want to TALK with you about your research to see if you have a good grasp of your project from start to finish. Besides asking the obvious questions, judges often ask questions to test your insight into your projects such as "What was your role?", "What didn't you do?" and "What would be your next step?"

JUDGING CRITERIA (points)

	<u>Individual</u>	<u>Team</u>
Creative Ability	30	25
Scientific Thought and Engineering Goals	30	25
Thoroughness	15	12
Skill	15	12
Clarity	10	10
Teamwork	--	16

Patent and Copyright Information

You may want to consider applying for a patent or copyright if you want to protect your work. You can contact the Office of Public Affairs, U.S. Patent Office, at 703/305-8341 for Patent information or the Library of Congress at 202/707-3000 for copyright information.

Important Student Requirement

- Each student may enter only one project, which covers research done over a maximum continuous 12-month period between January 2012 and May 2013.
- Students may compete in only one ISEF Affiliated Fair, except when proceeding to a state/national fair affiliated with the Intel ISEF from an affiliated regional fair.
- Any student in grades 9-12 or equivalent is eligible, none of whom has reached age 21 on or before May 1 preceding the Intel ISEF.
- Any student in grade 6-12 or eligible to compete in the CTSEF if approved by the CTSEF committee and qualified as a top winner placing 1st, 2nd, or 3rd at their local fair.
- The student researcher is responsible for all aspects of the research project including enlisting the aid of any needed supervisory adults (Adults Sponsor, Qualified Scientist, etc.), obtaining necessary approvals (SRC, IRB, PRT, etc.), following the Rules & Guidelines of the ISEF and The CTSEF, and doing the experimentation, engineering, data analysis, etc. involved in the project
- Scientific fraud and misconduct are not condoned at any level of research or competition. Such practices include plagiarism, forgery, use or presentation of other researcher's work as one's own and fabrication of data. Fraudulent projects will fail to qualify for competition in affiliated fairs or the Intel ISEF..

GUIDELINES FOR HYPOTHESES

RESEARCH HYPOTHESIS

A research hypothesis is the expected outcome of an experiment. It is a simple statement of what the researcher expects to find upon conducting a study. It is a specific and testable prediction, and must have some variables.

A researcher must consider all the possibilities about a relationship between variables that he/she has identified in his/her project. Using his/her background knowledge of the topic, the researcher should choose which prediction he/she thinks will most likely occur. It is usually a declarative statement, but an "if...then..." type of statement may also be used to express a hypothesis.

Examples:

A student wants to test whether a plant grows better in sunlight or artificial light. If s/he expects the plants to grow better in sunlight, his/her hypothesis might state:

"Plants exposed to sunlight will grow better than plants exposed to artificial light."

OR

A student wants to examine fecal coliform pollution in undisturbed and disturbed sediments in a local creek. His/her hypothesis might state:

"If the sediment in Blackwater Creek is disturbed, then the fecal coliform concentration in the water will be higher."

NULL HYPOTHESIS

A null hypothesis is a statement of what the researcher expects NOT to find. It is typically a hypothesis of "no difference." It is often the reverse of what she/he actually believes; it is put forward to allow the data to contradict it. The researcher never accepts the null hypothesis. The researcher's goal is to reject or fail to reject the null hypothesis through experimentation.

Examples:

A student wants to test the effect of increased carbon dioxide levels in the environment on plant growth. If s/he expects increased levels of CO₂ to result in more rapid plant growth, his/her null hypothesis might state:

"Increased levels of CO₂ in the environment will not result in more rapid plant growth."

OR

A student wants to conduct an experiment to see if starfish that are treated with a growth hormone will show a higher regeneration rate than starfish that are not treated. S/he randomly assigns 11 starfish each with one arm missing to one of two groups. The treatment group (5 subjects) receives the growth hormone and the control group (6 subjects) does not. His/her null hypothesis might state:

"There is no difference in the regeneration rates between the treatment groups receiving a growth hormone and the control group not receiving a growth hormone."

ADULTS INVOLVED IN A SCIENCE PROJECT

The Adult Sponsor (AS)

An Adult Sponsor may be a teacher, parent, university professor, or scientist in whose lab the student is working. This individual must have a solid background in science and should have close contact with the student during the course of the project.

The Adult Sponsor is ultimately responsible not only for the health and safety of the student conducting the research, but also for the humans or animals used as subjects. The Adult Sponsor must review the Checklist for Adult Sponsor (1), the student's Checklist (1A) and Research Plan to make sure that:

- a) experimentation is done within local, state, and federal laws, and the CTSEF Rules.
- b) forms are completed by other adults involved in approving or supervising any part of the experiment.
- c) criteria for the qualified scientist adhere to those set forth in the Guidelines for the Qualified Scientist.

The Adult Sponsor must be familiar with the regulations that govern potentially dangerous research as they apply to a specific student project. These may include chemical and equipment usage, experimental techniques, research involving human or nonhuman animals, and cell cultures, microorganisms, or animal tissues. The issues must be discussed with the student when completing the Research Plan. Some experiments involve procedures or materials that are regulated by state and federal laws. If not thoroughly familiar with the regulations, the Adult Sponsor should help the student enlist the aid of a Qualified Scientist.

The Adult Sponsor is responsible for ensuring that the student's research is eligible for entry in the CTSEF.

IF QUALIFIED:
AS = QS (Qualified Scientist)
AS = DS (Designated Supervisor)

The Qualified Scientist (QS)

A Qualified Scientist should possess an earned doctoral/professional degree in the biomedical sciences. However, a master's degree with equivalent experience and/or expertise is acceptable when approved by a Scientific Review Committee (SRC). The Qualified Scientist must be thoroughly familiar with the local, state, and federal regulations that govern the student's area of research. The Qualified Scientist and the Adult Sponsor may be the same person, **IF** that person is qualified as outlined above.

A student may work with a Qualified Scientist in another city or state. In this case, the student must work locally with a Designated Supervisor who has been trained in the techniques the student will use.

IF QUALIFIED:
QS = AS (Adult Sponsor)

The Designated Supervisor (DS)

The Designated Supervisor is an adult who supervises a student's experiment. In the case of hazardous substances or devices, a Designated Supervisor is directly responsible for overseeing student experimentation. A Qualified Scientist may or may not be necessary. The Designated Supervisor need not have an advanced degree, but should be thoroughly familiar with the student's project, and must be trained in the student's area of research. The Adult Sponsor may act as the Designated Supervisor.

If a student is experimenting with live vertebrates and the animals are in a situation where their behavior or habitat is influenced by humans, the Designated Supervisor must be knowledgeable about the humane care and handling of the animals.

IF QUALIFIED:
DS = AS (Adult Sponsor)

CATEGORY DESCRIPTIONS

The CTSEF and Intel ISEF categories are listed below:

Animal Sciences

- Animal Behavior
- Cellular Studies
- Development
- Ecology
- Genetics
- Nutrition and Growth
- Physiology
- Systematics and Evolution

Behavioral and Social Sciences

- Clinical & Developmental Psychology
- Cognitive Psychology
- Neuroscience
- Physiological Psychology
- Sociology and Social Psychology

Biochemistry

- Analytical Biochemistry
- General Biochemistry
- Medicinal Biochemistry
- Structural Biochemistry

Biomedical and Health Sciences

- Cell, Organ, and Systems Physiology
- Genetics and Molecular Biology of Disease
- Immunology
- Nutrition and Natural Products
- Pathophysiology

Biomedical Engineering

- Biomaterials and Regenerative Medicine
- Biomechanics
- Biomedical Devices
- Biomedical Imaging
- Cell and Tissue Engineering
- Synthetic Biology

Cellular and Molecular Biology

- Cell Physiology
- Cellular Immunology
- Genetics
- Molecular Biology
- Neurobiology

Chemistry

- Analytical Chemistry
- Computational Chemistry
- Environmental Chemistry
- Inorganic Chemistry
- Materials Chemistry
- Organic Chemistry

Physical Chemistry

Computational Biology and Bioinformatics

- Computational Biomodeling
- Computational Epidemiology
- Computational Evolutionary Biology
- Computational Neuroscience
- Computational Pharmacology
- Genomics

Earth and Environmental Sciences

- Atmospheric Science
- Climate Science
- Environmental Effects on Ecosystems
- Geosciences
- Water Science

Embedded Systems

- Circuits
- Internet of Things
- Microcontrollers
- Networking and Data Communications
- Optics
- Sensors
- Signal Processing

Energy: Chemical

- Alternative Fuels
- Computational Energy Science
- Fossil Fuel Energy
- Fuel Cells and Battery Development
- Microbial Fuel Cells
- Solar Materials

Energy: Physical

- Hydro Power
- Nuclear Power
- Solar
- Sustainable Design
- Thermal Power
- Wind

Engineering Mechanics

- Aerospace and Aeronautical Engineering
- Civil Engineering
- Computational Mechanics
- Control Theory
- Ground Vehicle Systems
- Industrial Engineering-Processing
- Mechanical Engineering
- Naval Systems

Environmental Engineering

- Bioremediation
- Land Reclamation
- Pollution Control
- Recycling and Waste Management
- Water Resources Management

Materials Science

- Biomaterials
- Ceramic and Glasses
- Composite Materials
- Computation and Theory
- Electronic, Optical, and Magnetic Materials
- Nanomaterials
- Polymers

Mathematics

- Algebra
- Analysis
- Combinatorics, Graph Theory, and Game Theory
- Geometry and Topology
- Number Theory
- Probability and Statistics

Microbiology

- Antimicrobial and Antibiotics
- Applied Microbiology
- Bacteriology
- Environmental Microbiology
- Microbial Genetics
- Virology

Physics and Astronomy

- Atomic, Molecular, and Optical Physics
- Astronomy and Cosmology
- Biological Physics
- Computational Physics and Astrophysics
- Condensed Matter and Materials
Instrumentation
- Magnetics, Electromagnetics, and Plasmas
- Mechanics
- Nuclear and Particle Physics
- Optics, Lasers, and Masers
- Quantum Computation
- Theoretical Physics

Plant Sciences

- Agriculture and Agronomy
- Ecology
- Genetics and Breeding
- Growth and Development
- Pathology
- Plant Physiology
- Systematics and Evolution

Robotics and Intelligent Machines

- Biomechanics
- Cognitive Systems
- Control Theory
- Machine Learning
- Robot Kinematics

Systems Software

- Algorithms
- Cybersecurity
- Databases
- Human/Machine Interface
- Languages and Operating Systems
- Mobile Apps
- Online Learning

Translational Medical Science

- Disease Detection and Diagnosis
- Disease Prevention
- Disease Treatment and Therapies
- Drug Identification and Testing
- Pre-Clinical Studies

Teams

ABSTRACT INSTRUCTIONS

The abstract form and the instructions below are intended for CTSEF participants. Please follow all local CTSEF regional instructions. If you are an Intel ISEF finalist, you will receive further information and will be required to complete this abstract in an on-line abstract system immediately after winning at the regional or state fair.

Writing Requirements

After finishing research and experimentation you are required to write a maximum **250-word, one page abstract**. The **official abstract form** can be found at: www.ctsef.org or www.societyforscience.org. Abstracts should be **single-spaced using 12-point type** from a black ribbon or laser cartridge. Abstracts may not exceed 250 words and must be typed within the predefined area (5.5" high by 6" wide). Type title (title case required), your first name, middle initial, last name, and school name, city and state in the first 7.5" of space within the box. Two lines may be used for the title. Teams must include all team member names.

Example: Effects of Marine Engine Exhaust Water on Algae
Mary E. Jones
Hometown High School, Hometown, State

BE SURE TO ANSWER ALL THE QUESTIONS BY MARKING THE APPROPRIATE BOXES, THEN SIGN AND DATE THE FORM.

The abstract must include:

- Purpose of the experiment
- Basic procedures
- Data summary
- Conclusions

The three common reasons that a student is asked to rewrite the abstract are:

1. Including acknowledgements (that includes naming the research institution and/or mentor with which you were working).
2. Describing research not completed by the student.
3. Describing research done in previous years. Only minimal reference to previous work may be included. Please limit yourself to describing research you have done in the current year.

Research Plan Guide

(Complete all areas below then upload to your student profile page section - Research Plan)

a. Rationale Statement:

b. Hypothesis(es), Research Question(s), Engineering Goal (see page 30 ISEF Rules and Guidelines):

c. Materials List:

d. Procedures: step by step details, risk and safety precautions, data analysis and presentation (include chart(s), diagram(s), survey, etc.)

e. Bibliography: List at least five (5) major references (science journal articles, books, and internet sites). If your project is using Vertebrate Animals, one of these references must be an animal care reference for your specific animal.

SRC Projects [not PRT]

SRC projects consist of experiments that deal with the following:

- vertebrate animals
- potentially hazardous biological agents
- hazardous chemicals, activities, or devices
- some human participant projects may require both SRC and IRB reviews

--All projects must be reviewed and approved before experimentation.--

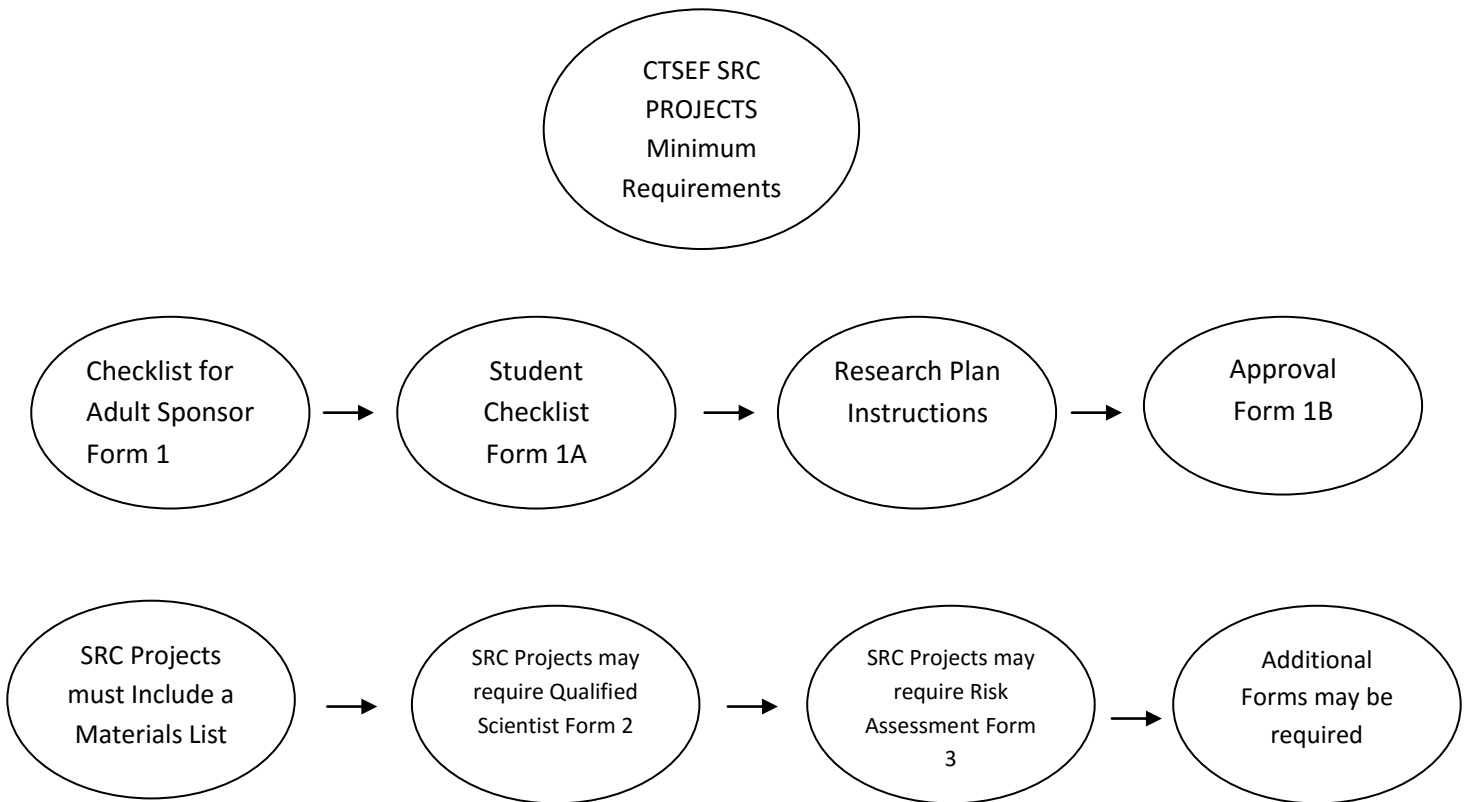

IRB Projects [not PRT]

IRB projects consist of experiments that deal with the following:

- all human participant projects
- some human participant projects may require both SRC and IRB reviews

--All projects must be reviewed and approved before experimentation.

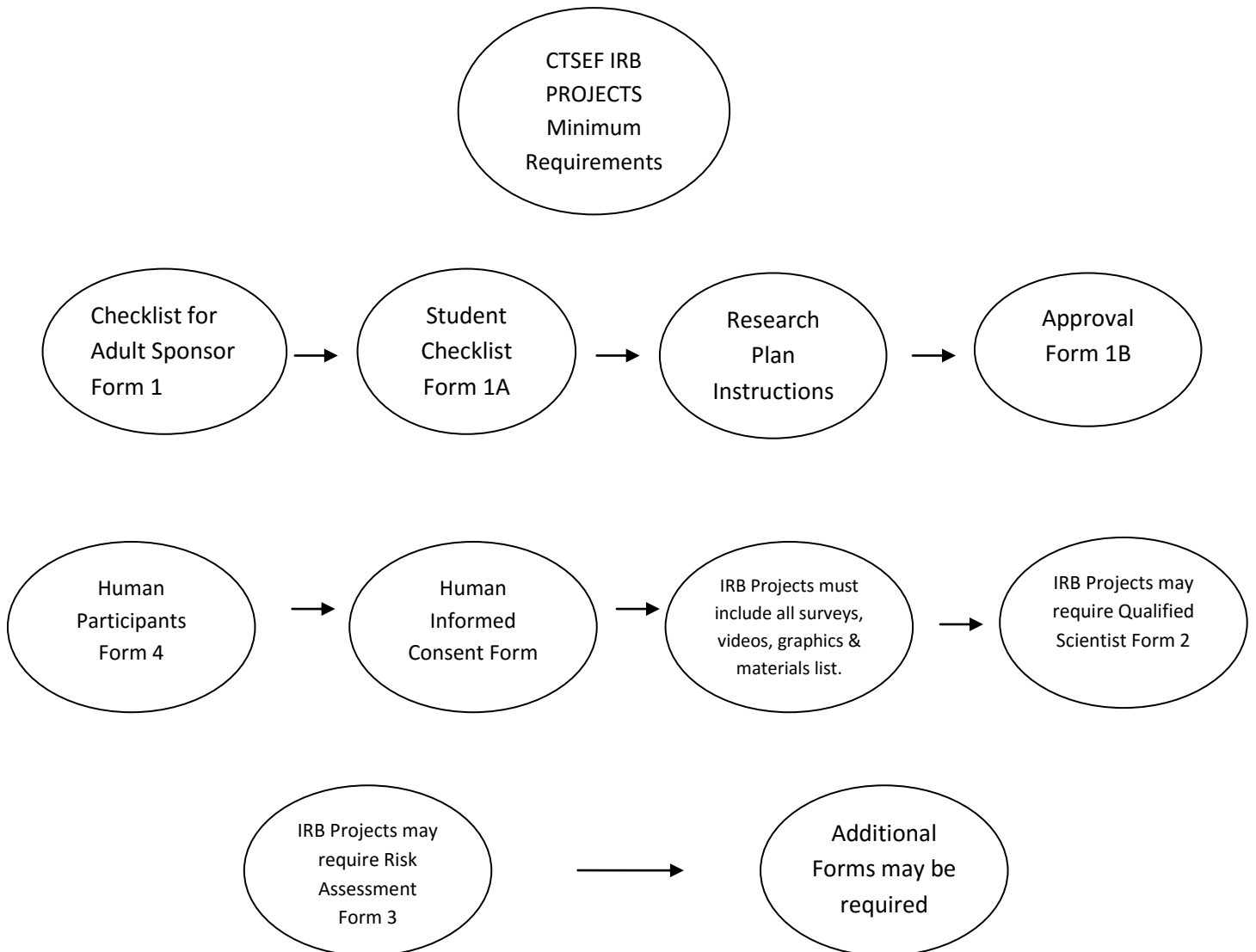

PRT Projects [not SRC or IRB]

PRT projects consist of experiments that are not SRC or IRB.

All projects must be reviewed and approved before experimentation.

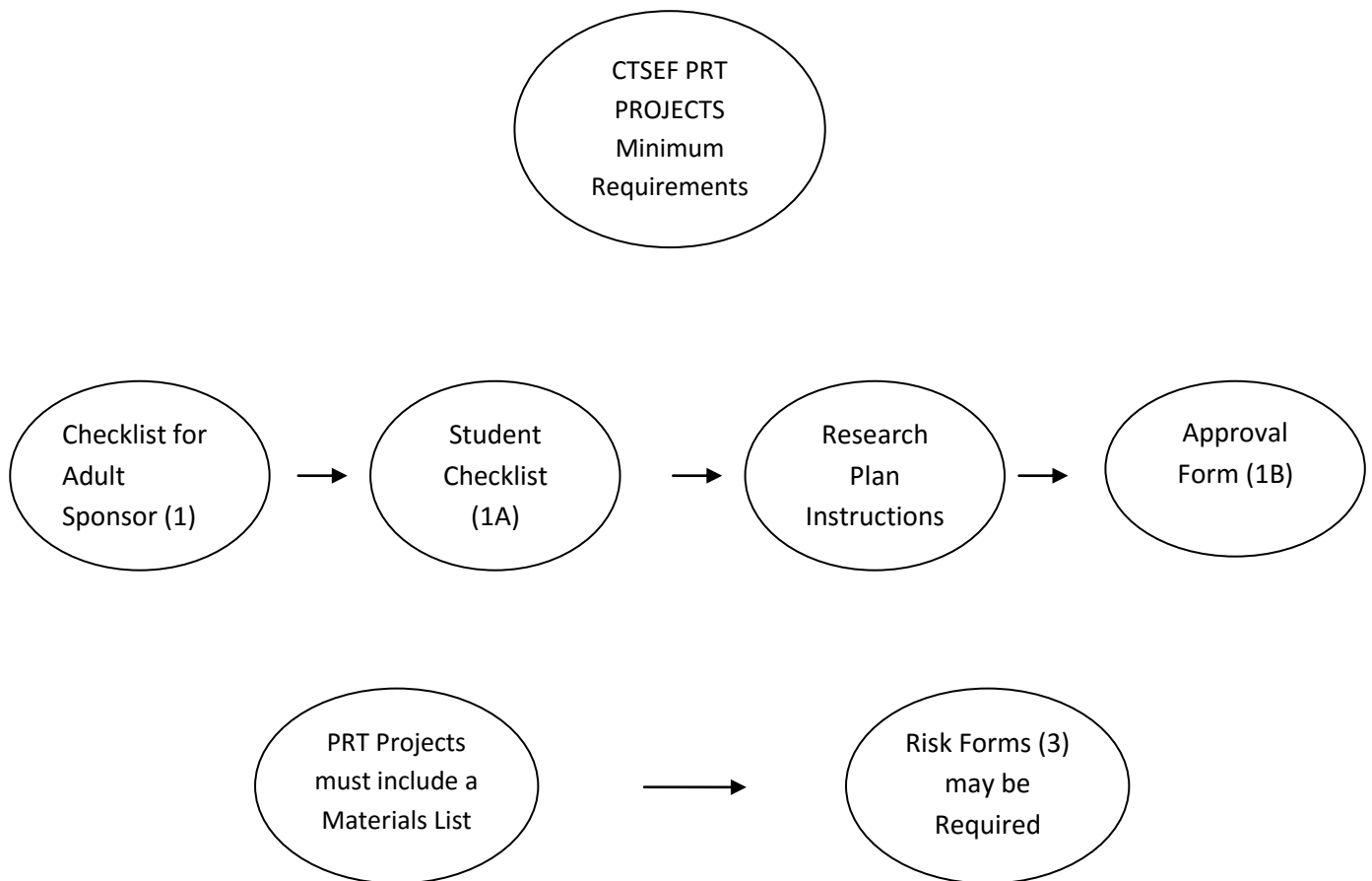

CTSEF Online Process

[www.ctsef.org]

CTSEF Online Teacher/Sponsor Profile Page - Complete Profile

CTSEF Online Student Profile Page - Complete Profile

Teacher/Sponsor reviews student's project from Teacher/Sponsor profile page.

Student will download waiver, then complete the waiver and save the document using the assigned CTSEF filing number. Return to your profile page and upload the saved waiver

Teacher pushes student's project to CTSEF review, if teacher is satisfied with the project, by CTSEF deadline date.

Download all ISEF forms following the instructions on your profile page. Complete only the forms needed for your project. If you need help ask your teacher or call the CTSEF office. Once the forms are completed and saved using the assigned CTSEF filing number, return to your profile page to upload, following the provided instructions.

If project is not complete, the Teacher/Sponsor returns student's project for corrections using the Teacher/Sponsor comment box -- repeat the above process until you are satisfied with the student's project. Once you feel the project is complete, submit to CTSEF review.

Research Plan – This you will have on your computer. The Research Plan should be in A, B, C order (following the Research Plan Instructions you downloaded earlier). Make sure to include your Bibliography and Materials List. Once you are ready to upload this document you will need to follow the instructions on your student profile page as before (using the assigned filing number).

CTSEF review is returned to the Teacher/Sponsor profile page as well as to the student's profile page.

If status is Online Complete, the Teacher/Sponsor will read and instruct student to final approval steps.

If you forgot to add any of your documents (graph/charts, etc.), you can upload them under the Add Section on your student profile page (follow instructions).

If status is Incomplete Resubmit, the Teacher/Sponsor will read and instruct student to make corrections and resubmit by deadline date.

The Teacher/Sponsor will have an ongoing invoice. There is a onetime fee for each student's review. The fee does not change regardless of number of reviews. This is only the filing fee and not the entry fee per student.

Once all areas are complete, your project is ready for review. Click the Submit for Review button (found at the top of your profile page). Your status will change to Under Review.

Waiver and Release of Liability

This Waiver and Release of Liability ("Waiver") is entered into

BY AND BETWEEN **Parent or Legal Guardian** (Please Print) _____

("Parent or Legal Guardian") having principal residence at _____

In the Parent or Legal Guardian's own interest and in the interest of the **Student** (Please Print) _____

("Student") having principal residence at _____

AND **Central Texas Science and Engineering Fair** ("CTSEF") and **Baylor University** ("Baylor"), and the terms "CTSEF" as used in this Waiver means the Central Texas Science and Engineering Fair, Inc. as an entity, its board members, directors, officers, employees, agents, its and their successors or assigns, including such board members, directors, officers, employees, agents, successors or assigns who participate in the Scientific Review Committee, the Regional IRB, or any other aspect of the Central Texas Science and Engineering Fair, Inc., and the term "Baylor" means Baylor University as an entity, and its regents, directors, officers, employees, agents, and students.

WITNESSETH

WHEREAS, Parent or Legal Guardian for the Parent or Guardian's own interest and the interest of Student promises to abide by the terms of this Waiver and offers as consideration for such Waiver the relinquishment of any right, suit, or claim for damages against CTSEF or Baylor or both; and

WHEREAS, CTSEF and Baylor promises to provide a forum for the presentation of the Student's science project and pledges such promise as consideration for this Waiver;

NOW THEREFORE

In consideration of the above-recited agreements and intending to be bound by this agreement:

- I. **COVENANT NOT TO SUE:** Parent or Legal Guardian covenants and agrees, for the Parent or Legal Guardian's own interest, the Parent or Legal Guardian's heirs, legal representatives, and assigns and as the legal representative of the Student, to irrevocably bind their interests to refrain from making any claim or demand, from commencing, causing, or permitting to be prosecuted any action in law or equity against the CTSEF or Baylor or both on account of any personal injury, injury to reputation, misrepresentation, breach of contract, or other damages, real or imaginary, known or unknown, which the Student or Parent or Legal Guardian ever had, have had, or which may have in the future.
- II. **WAIVER IS A DEFENSE TO ANY ACTION:** Parent or Legal Guardian for the Parent or Legal Guardian's own interest and the interest of the Student expressly agrees that this Waiver may be treated as a complete defense to any action or proceeding that may be brought, instituted, or taken by the Parent or Legal Guardian for the Parent or Legal Guardian's own interest and the interest of the Student or on their behalf against the CTSEF or Baylor or both and shall forever be a complete bar to the commencement or prosecution of any action or proceeding whatever against the CTSEF or Baylor or both.
- III. **RELEASE:** Parent or Legal Guardian for the Parent or Legal Guardian's own interest and the interest of the Student hereby releases, remises, and forever discharges CTSEF and Baylor from any and all actions, suits, payments, damages, claims, and demands of whatsoever kind, at law or equity, which Parent or Legal Guardian for the Parent or Legal Guardian's own interest and the interest of the Student ever had, have, or which may hereafter arise, or by reason of any other cause, matter, or thing whatsoever from the beginning of the world to the date of these presents.
- IV. **INDEMNIFICATION OF CTSEF:** Parent or Legal Guardian expressly agrees to indemnify CTSEF and Baylor against all forms of loss, including attorney fees and damage to reputation or goodwill, from any and all future claims, demands or actions that may hereafter be brought against CTSEF or Baylor or both by the Student or anyone in the Student's behalf, for the purpose of enforcing a further claim for damages.
- V. **RECOGNITION OF PARENTAL OR LEGAL GUARDIAN'S RESPONSIBILITY:**
 - A) Parent or Legal Guardian understands and acknowledges that science and engineering projects can involve and expose danger to the Student, to the Student's assistant, teacher, qualified scientist, or volunteers, to other persons helping the Student with such science or engineering project, or the person of the Parent or Legal Guardian.
 - B) Parent or Legal Guardian understands that the Student has voluntarily agreed to participate in the preparation of a science or engineering project and has chosen the area of study.
 - C) Parent or Legal Guardian fully understands and acknowledges that the Parent or Legal Guardian is solely and individually responsible for the safety and well-being of the Student or any third person involved in any aspect of such science or engineering project as well as any property damage that may occur as a result of such science or engineering project.
- VI. **ACKNOWLEDGMENT:** I, the above named Parent or Legal Guardian, have fully read and understand the terms of this agreement and freely and voluntarily agree to bind myself and the interests of the Student by the terms of this Waiver as signified by my signature.

ALL projects must be submitted online for review using the CTSEF website: www.ctsef.org

Once your project is online complete you will need to follow instructions (found on each student profile page) to receive final approval before experimentation may begin.

No student may begin experimentation until he/she has received APPROVED stamped on the Checklist for Adult Sponsor (1) Form.

www.societyforscience.org/isef
www.ctsef.org

Central Texas Science and Engineering Fair, Inc.
One Bear Place #97356 - Waco, Texas 76798
Baylor University
Cashion Building – Suite 307
Telephone: (254) 710-3169
Email: science_fair@baylor.edu
Website: www.ctsef.org